



CONDENSING TANKLESS GAS WATER HEATER



Service Manual

Models

199,000Btu / 180,000Btu

- Natural Gas(NG) / Liquid Propane Gas (LP)



WARNING

If the information in these instructions is not followed exactly, a fire or explosion may result, causing property damage, personal injury, or death.

- Do not store or use gasoline or other flammable vapors and liquids in the vicinity of this or any other appliance.
- WHAT TO DO IF YOU SMELL GAS
 - Do not try to light any appliance.
 - Do not touch any electrical switch; do not use any phone in your building.
 - Immediately call your gas supplier from a neighbor's phone. Follow the gas supplier's instructions.
 - If you cannot reach your gas supplier, call the fire department.
- Installation and service must be performed by a qualified installer, service agency or the gas supplier.

<u>Chapter 1</u>	Product Characteristics	Specifications	6
		Dimensions	7
		Names of Components	8
		Hot Water Supply Capability	9
		Pressure Loss Characteristics	10
		Operating Principle	11
		Timing Logic	13
		Operation Flow Chart	14
		Freeze Protect Flow Chart	15
		Wiring Diagram	16
<u>Chapter 2</u>	Components Description	Circuit Board	21
		Temperature Thermistors	22
		Overheat Limit Switch	23
		Water Leakage Detector	24
		Gas Leak Detector Sensor	25
		Air Pressure Switch	26
		Flow Control Valve	27
		Flow Sensor	28
		Igniter	29
		Flame Detection Sensor	30
		AGM	31
		Gas Valve	32
		Fan	33
		Metal Fiber Premix Burner	34
		Water Mixing Valve	35
		Circulation Pump	36
		DHW Inlet Filter	37
		Heat Exchanger	38
		Condensate Trap	39
<u>Chapter 3</u>	How to Use The Control Panel	Control Panel Interface	40
		Control Panel Display	41

	Changing the DHW Set Point	41
	Status Display Mode	42
	Changing The Time	43
	Installer Mode	44
	Recirculation Mode	45
	Set the Recirculation Timer Type	47
	Setting the Recirculation Run Time	48
	Resetting The Recirculation Run Time	49
<u>Chapter 4</u>	Troubleshooting	
	Error Code List	55
	Error 10	56
	Error 11	57
	Error 16	57
	Error 20	58
	Error 29	59
	Error 31	60
	Error 32	61
	Error 33	62
	Error 35	63
	Error 39	64
	Error 40	65
	Error 41	66
	Error 43	67
	Error 45	68
	Error 60	69
	Error 61	70
	Error 65	71

		Error 66	72
		Error 67	73
		Error 72	74
		Error 73	75
		Error 76	76
		Error 78	77
		Error 94	78
<u>Chapter 5</u>	Replacement Instructions	1. Circuit Board	79
		2. Igniter	80
		3. Flame Detection Sensor	81
		4. Gas Leak Detector	81
		5. Air Pressure Switch	82
		6. Gas Valve	83
		7. Flow Control Valve	84
		8. Water Mixing Valve	85
		9. Circulation Pump	86
		10. AGM	87
		11. Fan Assembly	88
		12. Heat Exchanger	89
<u>Chapter 6</u>	Maintenance	1. Cleaning the Water Heater	92
		2. Maintenance Procedures	93
		3. Flushing the Water Heater	95
<u>Chapter 7</u>	Components Diagram	Part I _ Case Part	96
		Memo	97

■ Specifications

Model Name		RTGH-RH11DV		RTGH-RH10DV		
Gas Input Rate	MAX	199,000 Btu/h		180,000 Btu/h		
	MIN	18,000 Btu/h		18,000 Btu/h		
	High Altitude (2,500~4,500ft)	180,000 Btu/h		180,000 Btu/h		
Hot Water Capacity	35°F Rise	11.0 Gal		9.9 Gal		
	45°F Rise	8.5 Gal		7.7 Gal		
	77°F Rise	5.0 Gal		4.5 Gal		
Installation		Indoor Wall Hung				
Flue System		Sealed Combustion Direct Vent, Single Vent				
Max Vent Run		2"(50ft) / 3"(100ft) Schedule 40 PVC, CPVC, PP				
Orifice Size	NG (Gas / Needle)	0.342"(8.7mm) / 0.354"(9.0mm)				
	LP (Gas / Needle)	0.263"(6.7mm) / 0.267"(6.8mm)				
Gas Supply Pressure	NG	5.0" W.C to 10.5" W.C				
	LP	9.5" W.C to 13.0" W.C				
Manifold Pressure	Gas Type		NG	LP	NG	LP
	Low Fire	2" VENT	-0.07" W.C	-0.02" W.C	-0.07" W.C	-0.02" W.C
		3" VENT	-0.07" W.C	-0.02" W.C	-0.07" W.C	-0.02" W.C
	High Fire	2" VENT	-0.38" W.C	-0.3" W.C	-0.36" W.C	-0.28" W.C
3" VENT		-0.33" W.C	-0.25" W.C	-0.31" W.C	-0.23" W.C	
Power Supply	Main Supply		120V 60Hz			
	Maximum Power Consumption		172W(82W+90W_PUMP)			
Ignition System		Direct Electronic Ignition / Automatic Flame Sensing				
Burner System		Premixed Metal Fiber Burner				
Gas Valve System		Air ratio valve				
Minimum Flow Activation Flow		0.5 GPM				
Internal Pipe Material		STS 304, Copper Tubing				
Dimensions		W17.3" – H28.7" – D14.8"				
Weight		85 lbs				
Water Holding Capacity		Under 2 Gallon				
Control Panel / Main Controller		P-950C / NGTH-9700C				
Water Pressure	MAX	Hot water 150 psi				
	MIN	15 psi				
Materials	Casing	Cold Rolled Carbon Steel				
	Heat Exchanger	Heat Exchanger : STS 304				
Safety Devices		Flame Sensor, Overheat Cut Off Limit Switch , Gas Leak Detector sensor, Water Leak Detector Sensor Exhaust Temperature Sensor, Water Temperature Sensor				

■ Dimensions

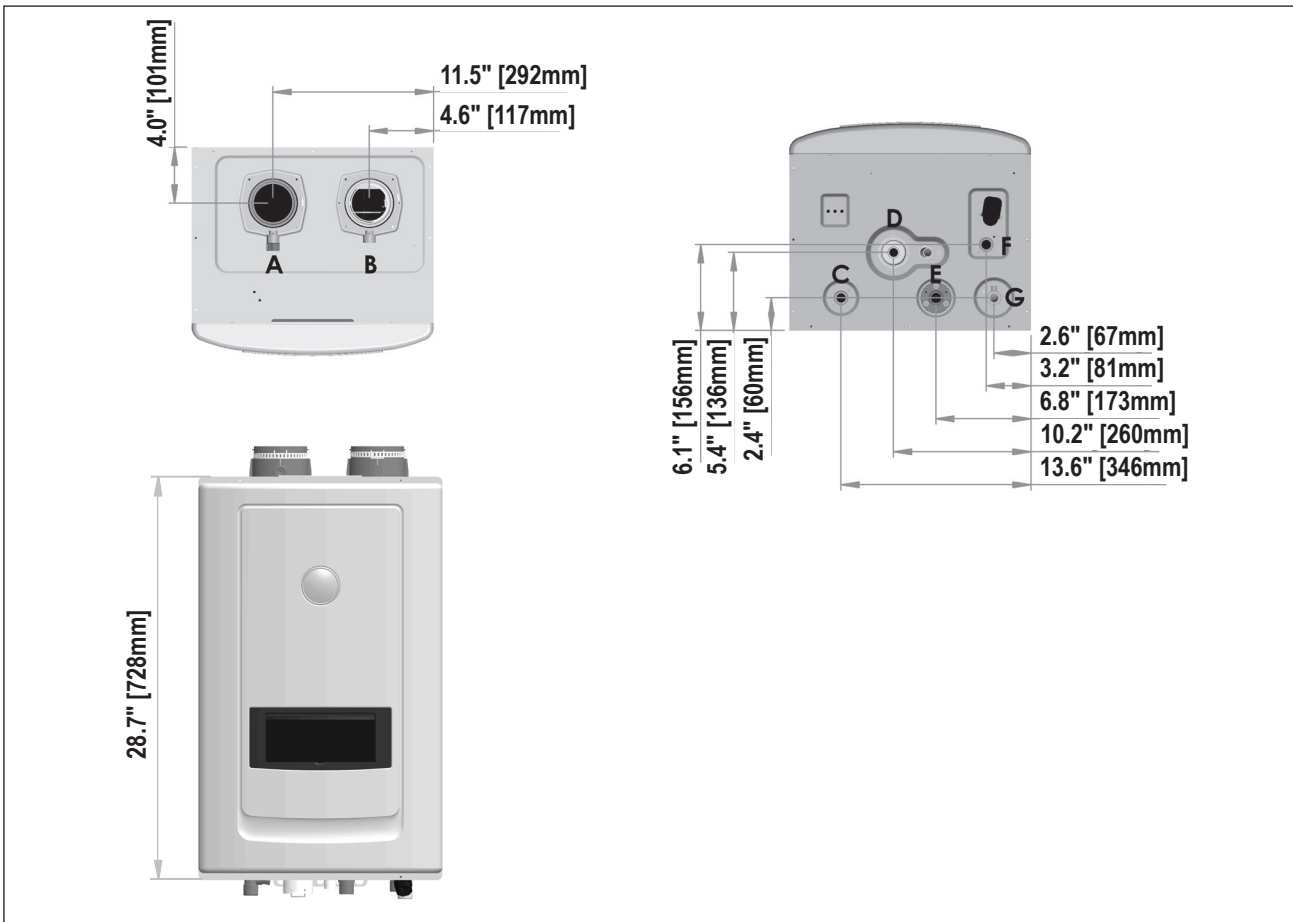

	DESCRIPTION	DIAMETER
A	Exhaust Outlet Pipe	3" (7.6 cm)
B	Air Intake	3" (7.6 cm)
C	DHW Outlet Adapter	3/4" (1.9 cm)
D	Condensate Adapter	1/2" (1.2 cm)
E	Recirculation Return	3/4" (1.9 cm)
F	DHW Inlet Adapter	3/4" (1.9 cm)
G	Gas Inlet	3/4" (1.9 cm)

■ Name of Components

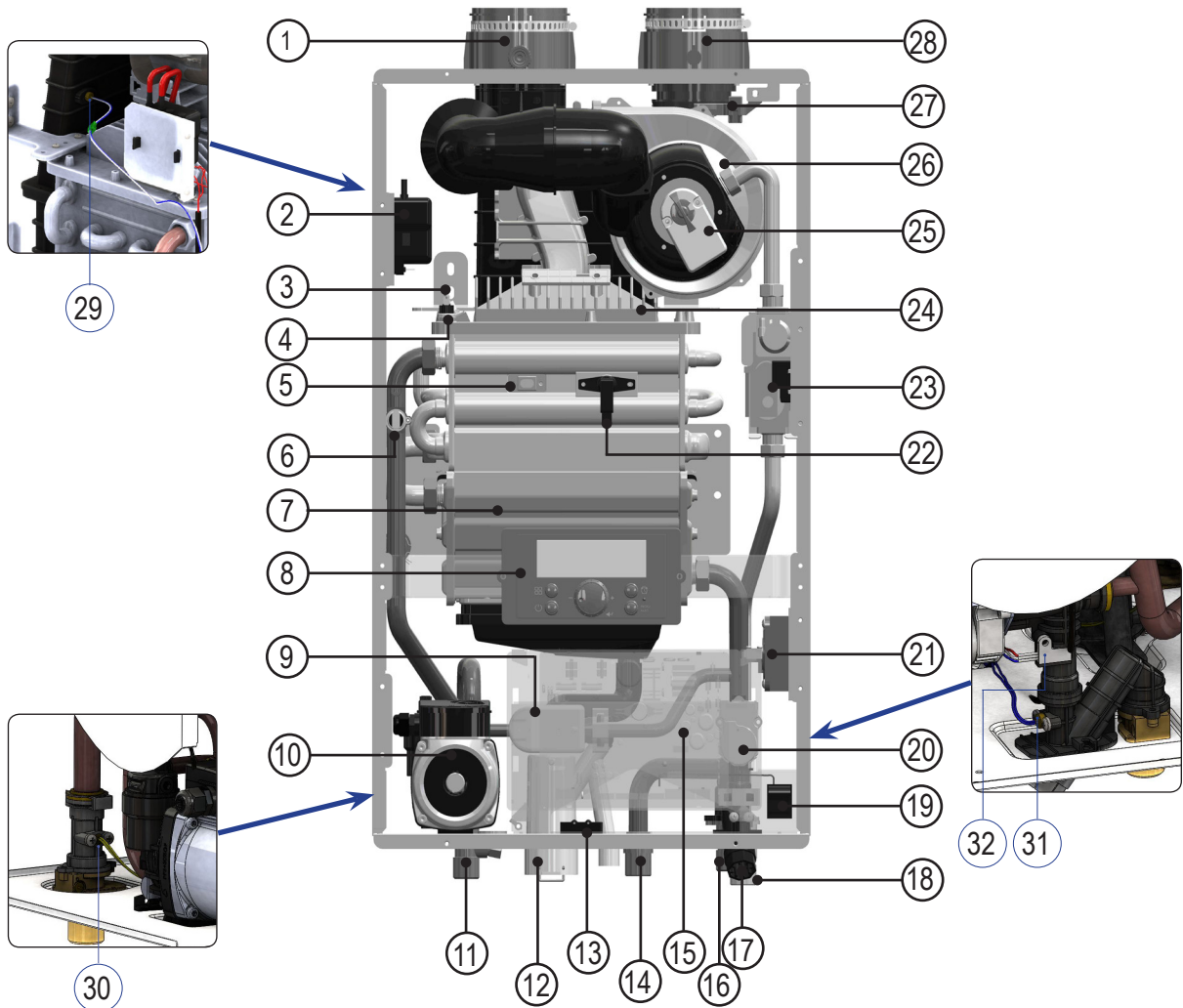

NO	Name of Component
1	Exhaust Outlet Collar
2	Ignition Trans
3	Ignition Rod
4	Over-heating Switch
5	Primary Heat Exchanger
6	H/E Temperature Sensor
7	Secondary Heat Exchanger
8	Control Panel
9	Mixing Valve
10	Recirculation Pump
11	'DHW' supply Adapter
12	Condensate Trap
13	Low level sensor
14	Recirculation Return Adapter
15	Main Controller
16	'DHW' Inlet Filter

NO	Name of Component
17	'DHW' Inlet Adapter
18	Gas Inlet Adapter
19	Manual Power Switch
20	Water Flow Control Valve
21	Air Pressure Switch
22	Flame Detection Sensor
23	Gas Valve
24	Burner Case
25	AGM(Air Gas Mixer)
26	BLDC Fan
27	Air Intake Filter
28	Air Intake Collar
29	Exhaust Thermistor
30	Heat Exchanger Thermistor
31	Cold Water Thermistor
32	Flow Sensor

Hot Water Supply Capability

199,000Btu/hr

180,000Btu/hr

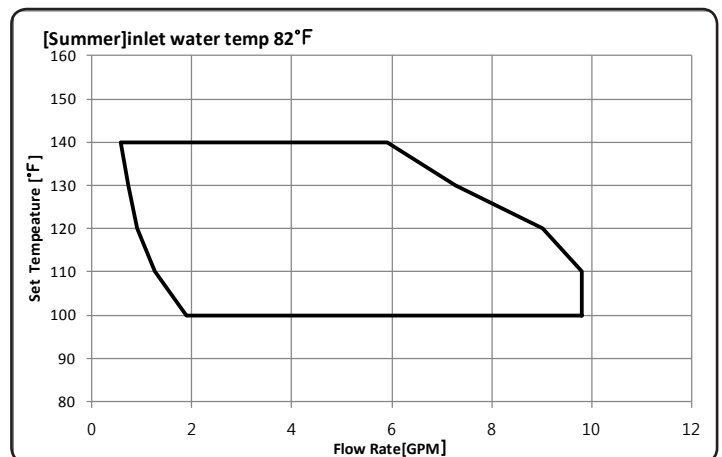
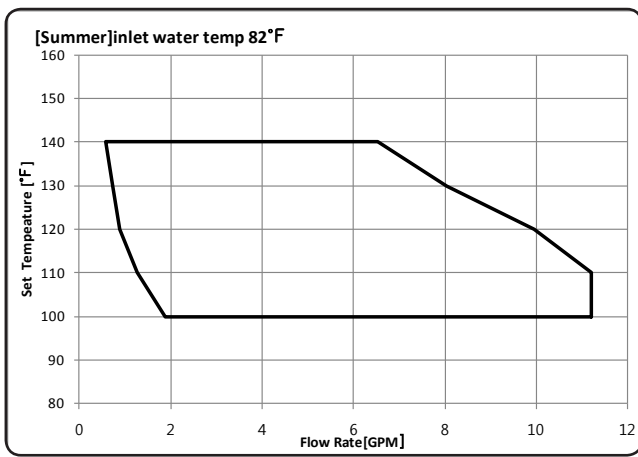
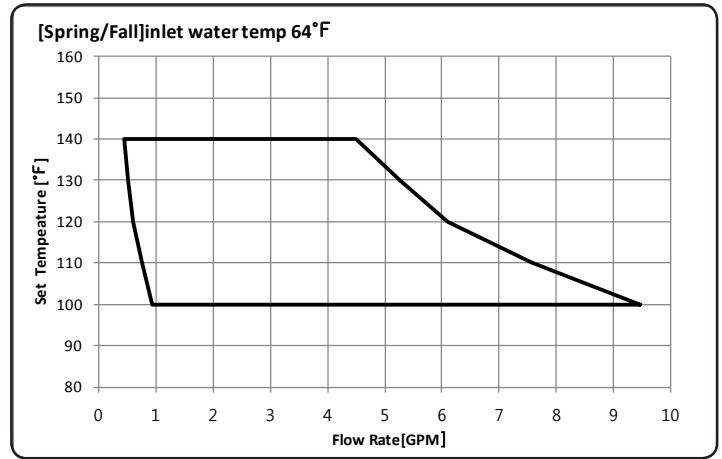
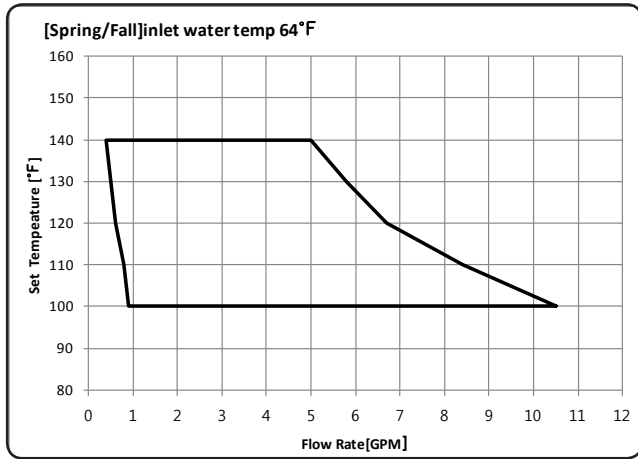
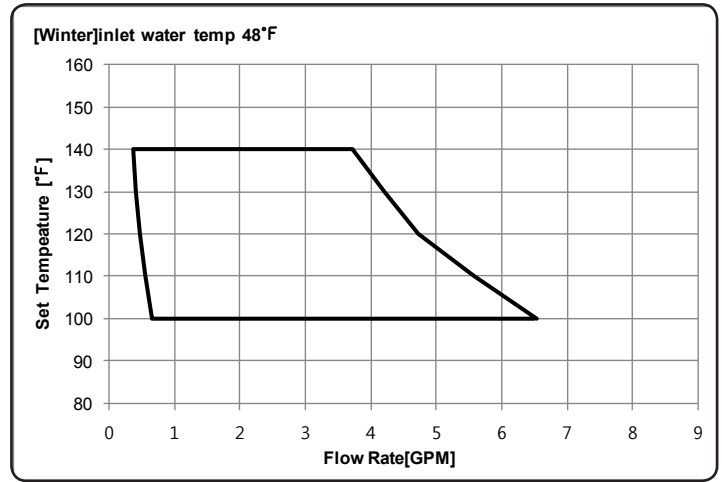
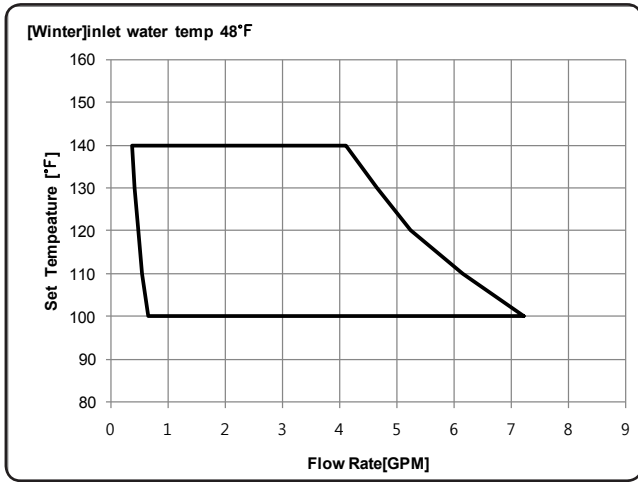

■ Pressure Loss Characteristics

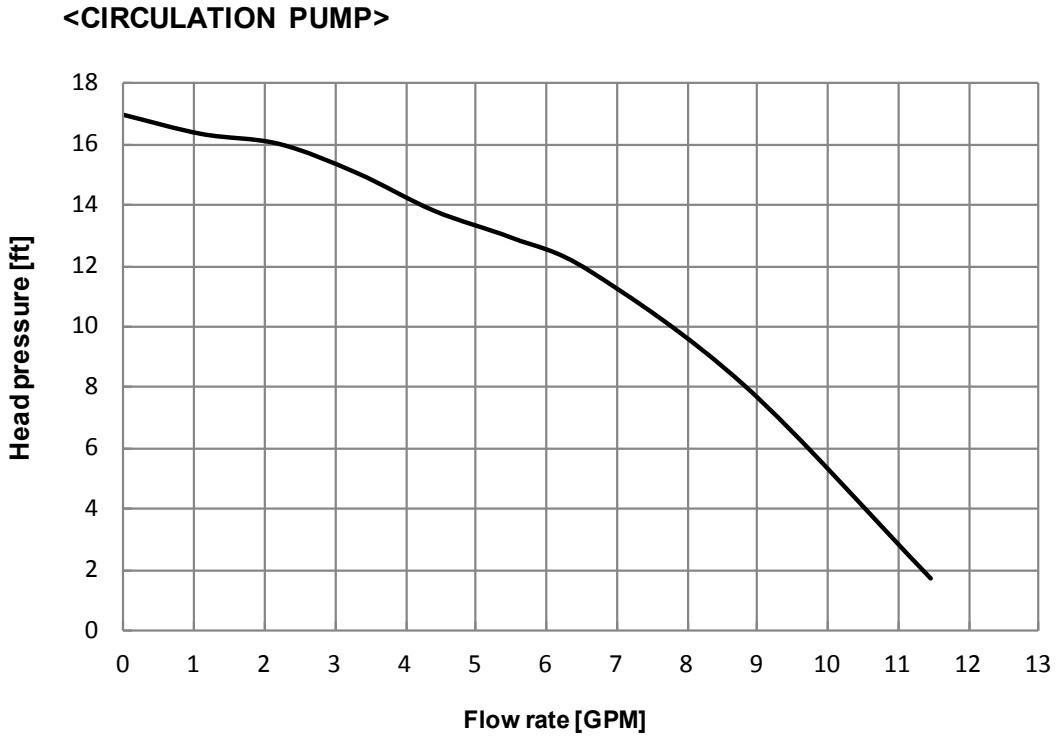
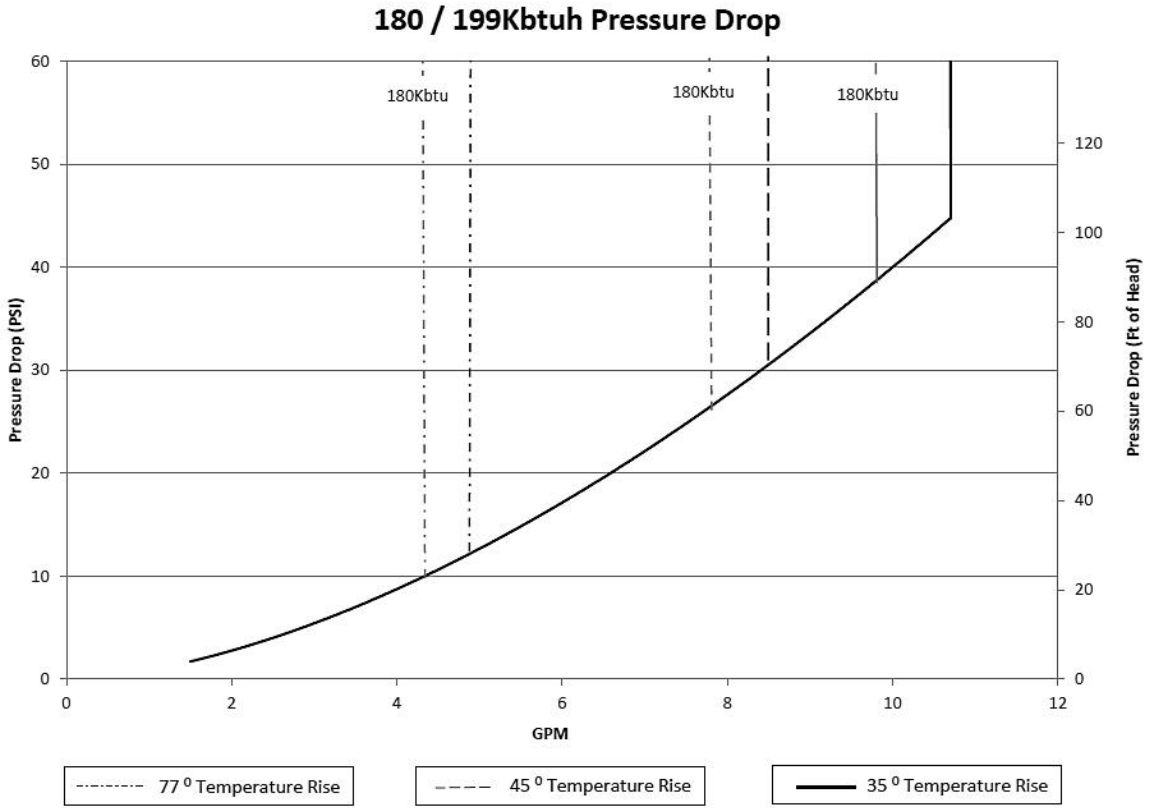

■ Operating Principle (Standard/External Mode)

Standard Mode

1. Only POTABLE water may be plumbed through the water heater.
2. The water heater cannot be used for space heating applications.
3. Expansion tank is required if a backflow preventer is installed.
4. Isolation valve kits are recommended for this installation.

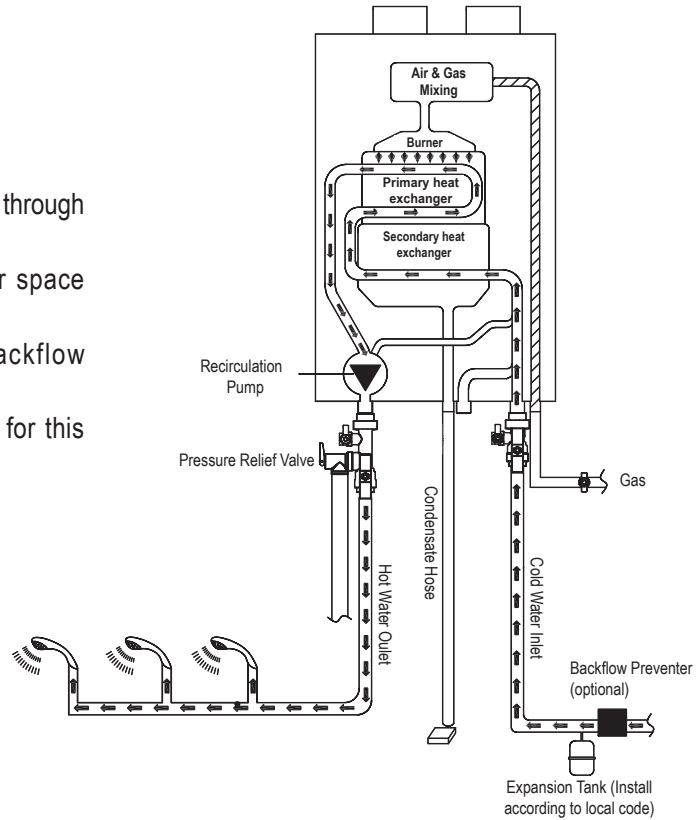

External Recirculation mode

The recirculation pipe must be installed in the field in order to use 'External Recirculation Mode'. This mode allows the water heater to recirculate heated water through the system and additionally serves as a freeze protection function.

When using external recirculation mode with the built-in pump, check the following maximum recirculation pipe lengths including fittings (3/4" pipe is recommended):
 -1/2" Pipe- 200' (60m) of equivalent length
 -3/4" Pipe- 500' (150m) of equivalent length
 Lengths in excess of these limits will require an external recirculation pump.

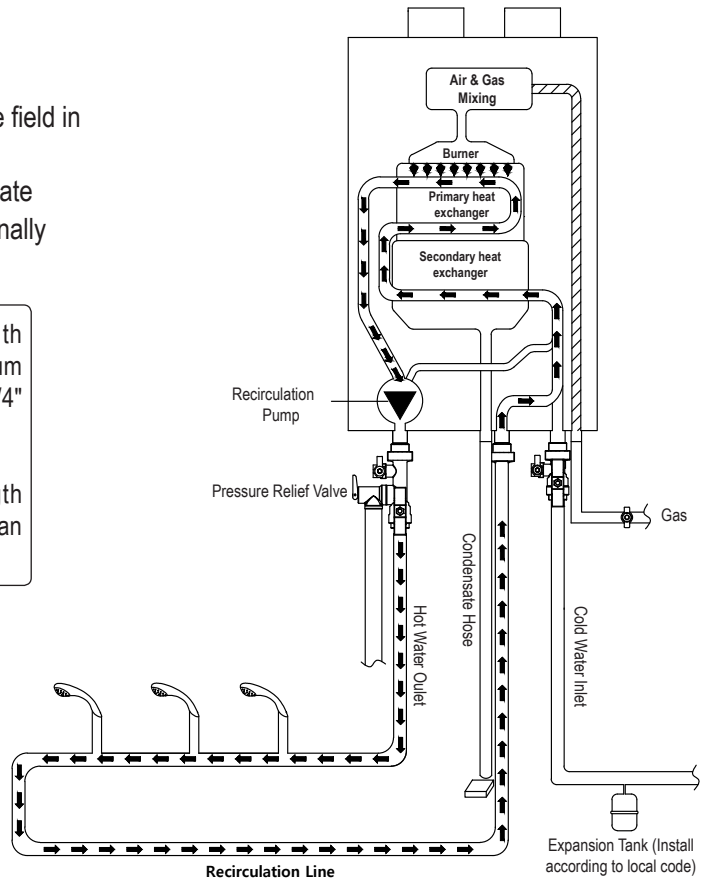

Operating Principle (Preheat or Internal Mode/ bYPS Recirculation Mode)

Preheat or Internal Recirculation Mode

Preheat or Internal Recirculation Mode may be used without an installed recirculation pipe. The water heater is preheated and protected from freezing.

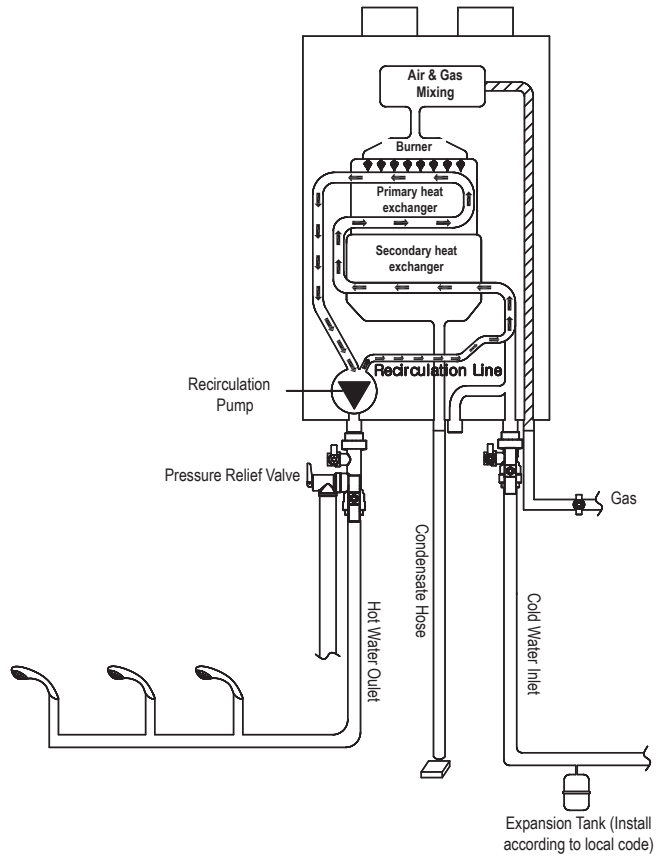

bYPS Recirculation Mode with Cross Over Valve

bYPS Recirculation Mode may be used with a cross over valve assembled at the furthest fitting

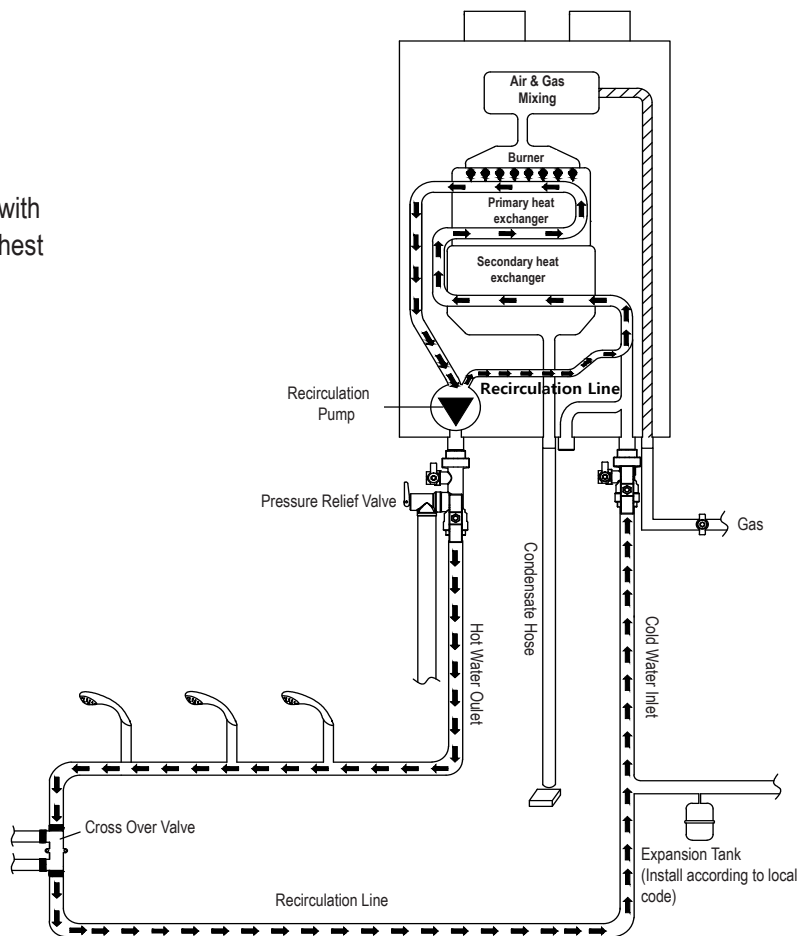

■ Timing Logic

■ Normal Ignition

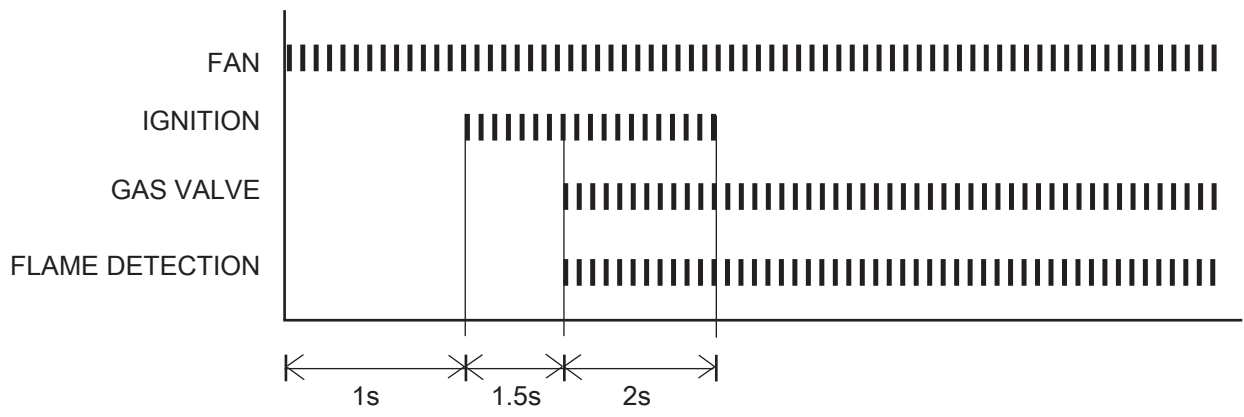

■ Normal Shutdown

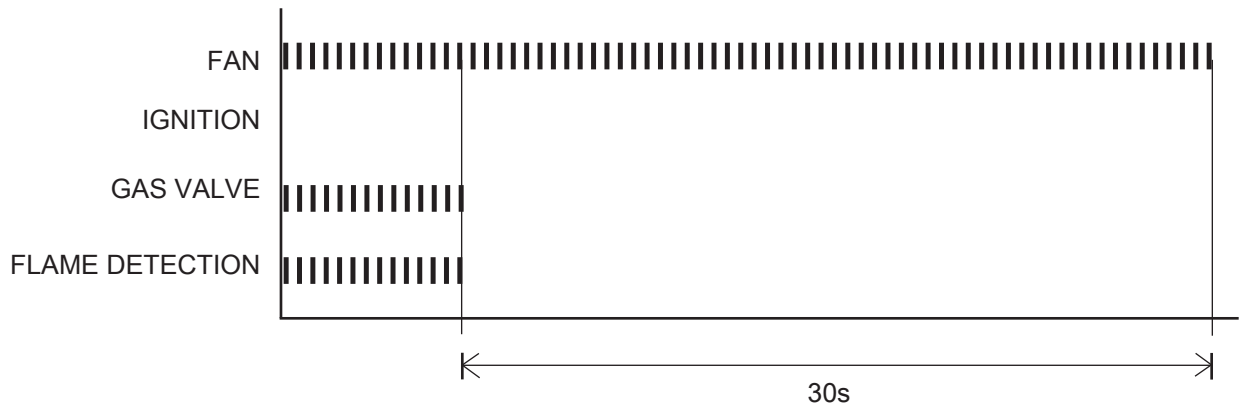

■ Ignition Failure (Error Code after 10 times)

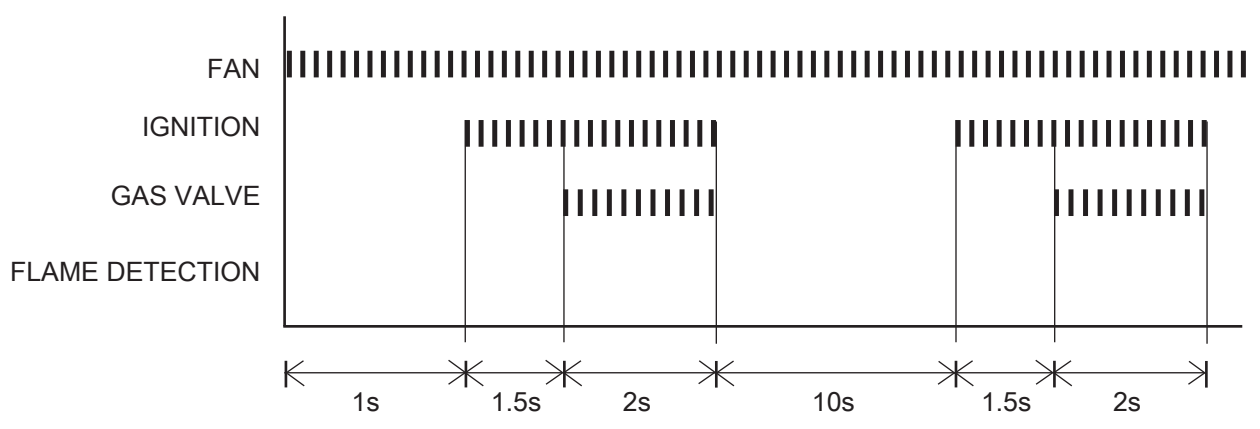

Hot Water Mode Flow Chart

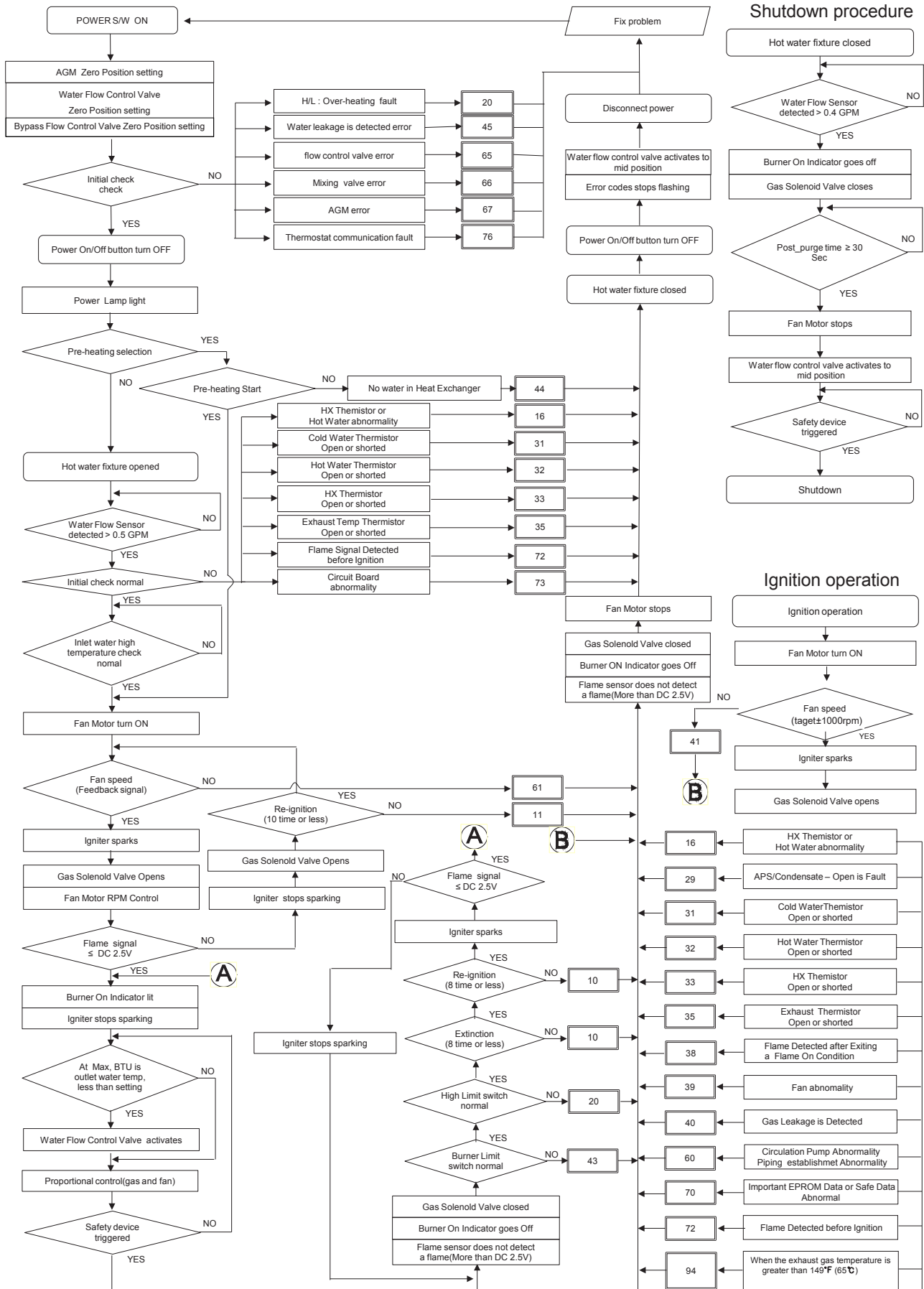

Freeze Protect Flow Chart

Freeze Prevention control flow

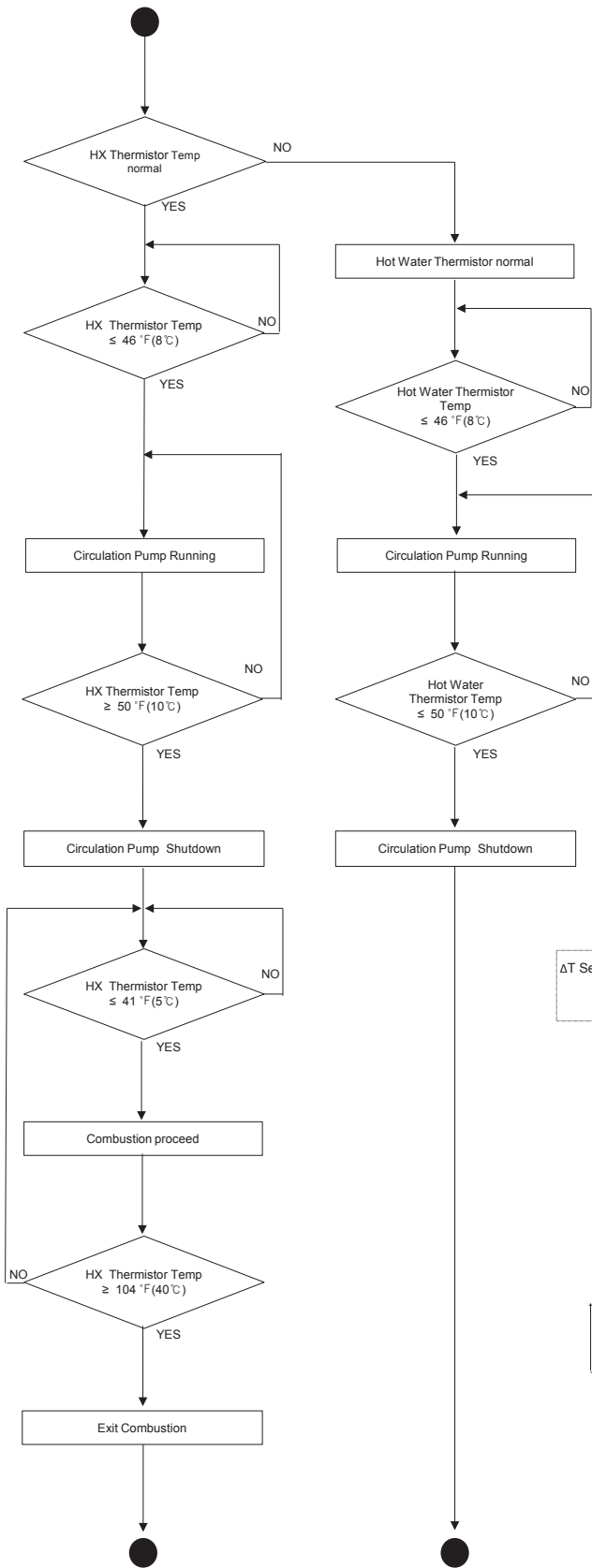

Water leakage operation flow

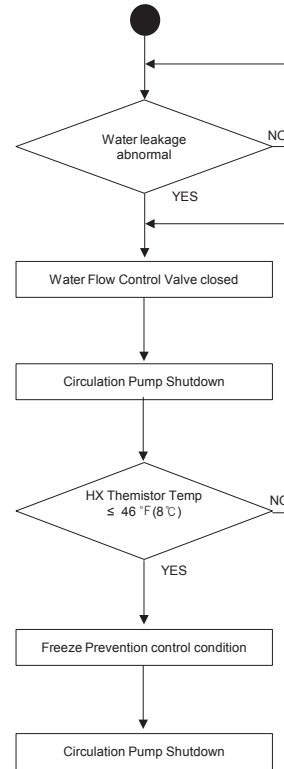

Pre-heating mode operation flow

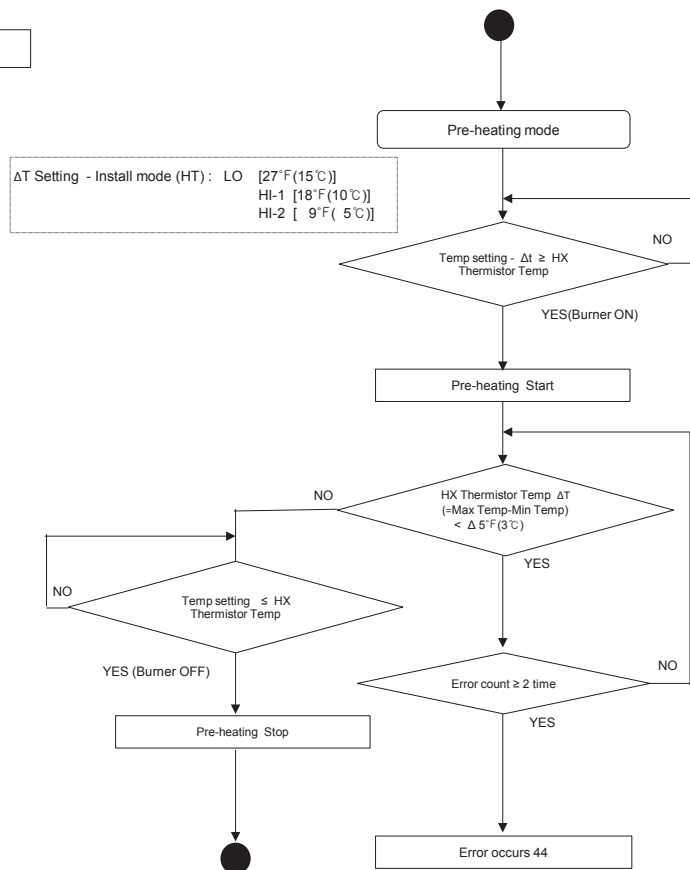

■ Wiring Diagram

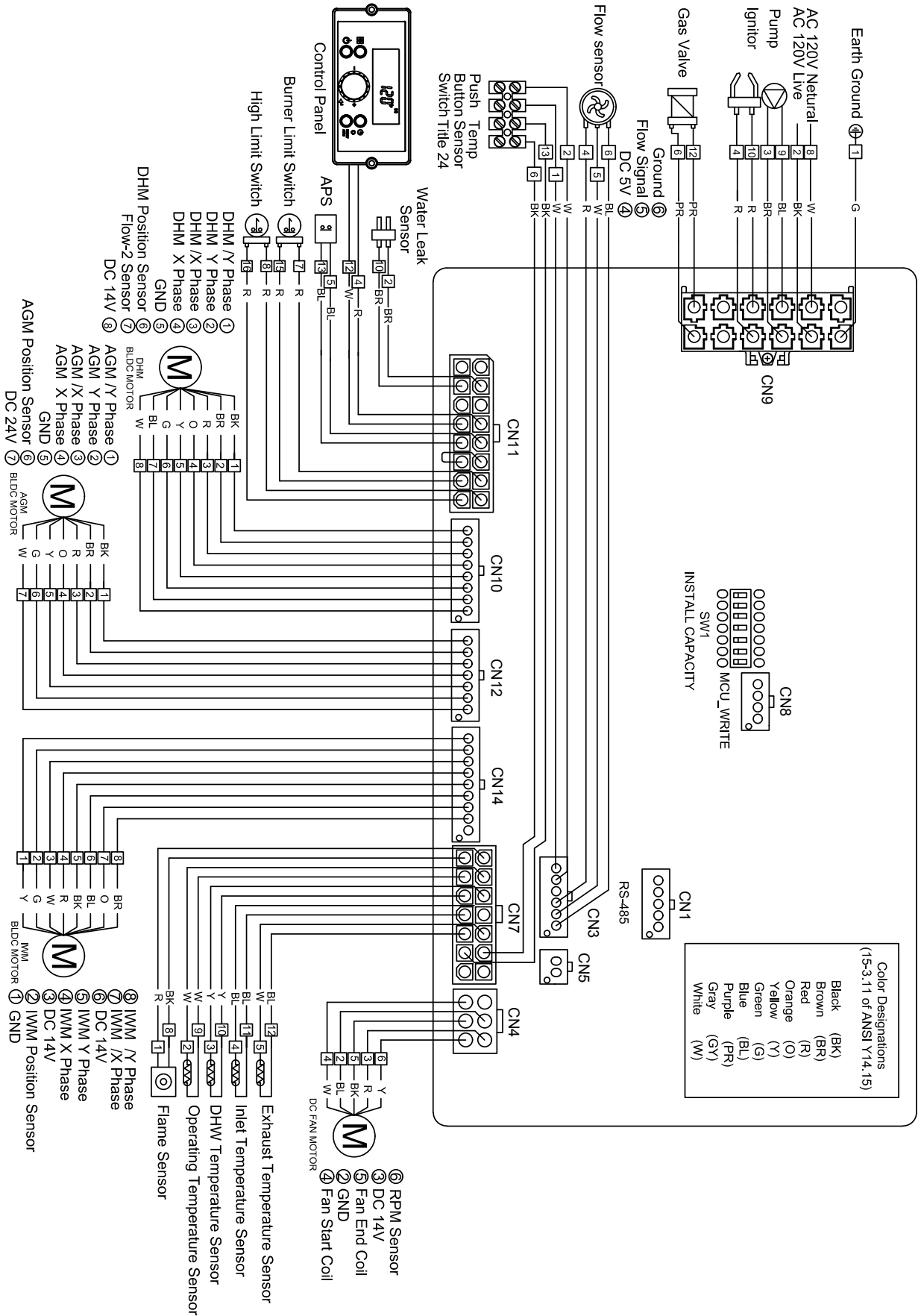

■ Ladder Diagram

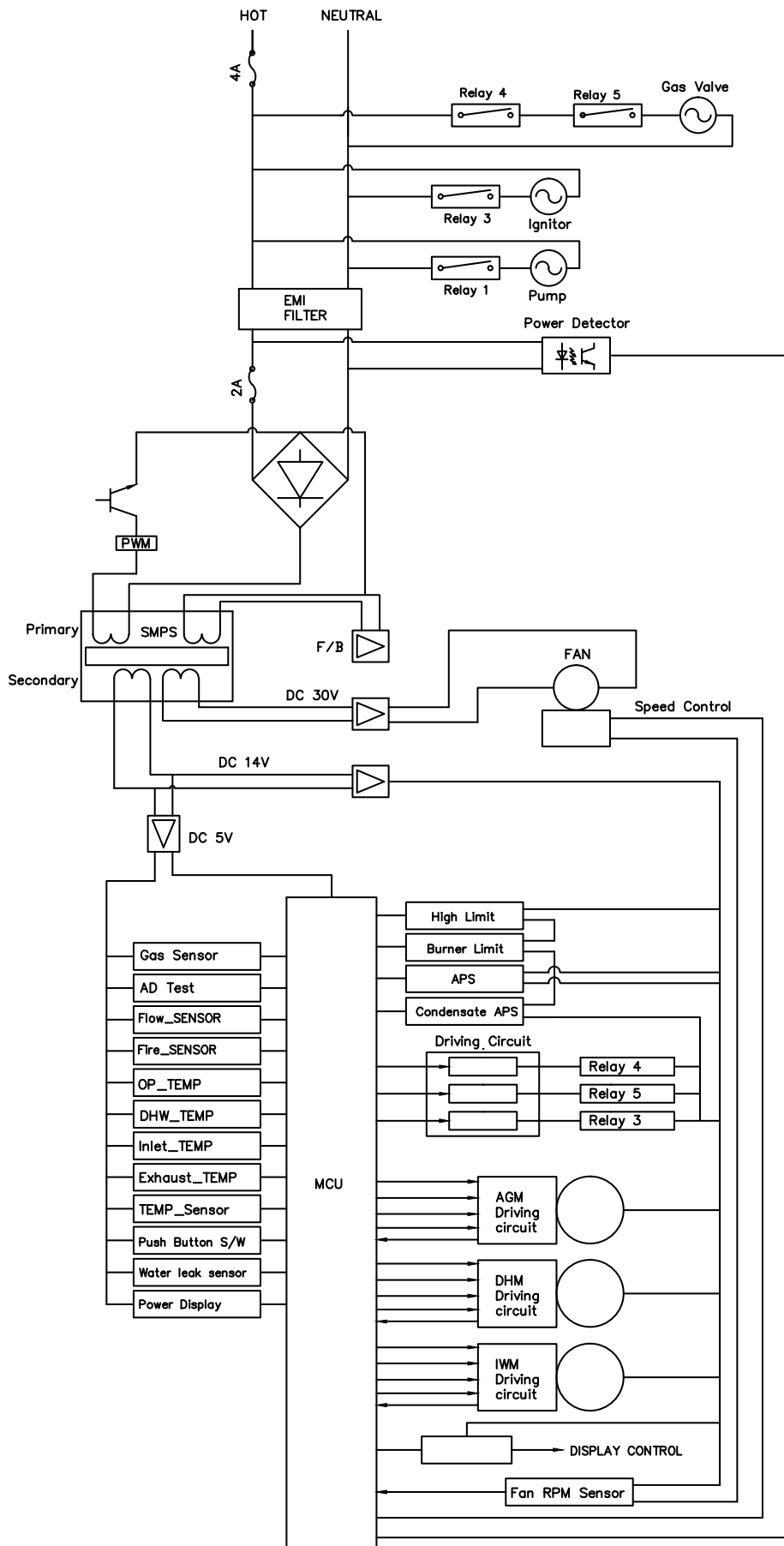

CONNECTOR			DESCRIPTION	HT SELV
NO. OF LOCATION	PIN	BOARD SILK		
CN9 65001WS-12	1	-	EARTH GROUND	-
	2	L	Power Supply Line	HT (120V~)
	3	CP1	Circulation Pump	
	4	IT	Igniter	
	5	L(HT)	UNUSED	
	6	GV	Gas Valve	
	7		UNUSED	
	8	N	Power Supply Neutral	
	9-12	┌ N ┐	AC Power COM Line	
CN1 SMW250-03	1	RS-485	RS485 +	
	2		GND	
	3		RS485 -	
CN4 LWD1140-06	1	FAN	Unused	-
	2		GND	SELV (30V)
	3		VDD	SELV (14V)
	4		Fan power (start coil)	SELV (30V)
	5		Fan power (end coil)	
	6		Fan speed feedback signal	SELV (5V)
CN8 SMW250-04	1	MCU ISP	GND	SELV (5V)
	2		ISP / Reset Port	
	3		ISP TOOL0 Data Port	
	4		VCC	
CN11	1	HWL	Unused	SELV(12V~)
	9		Unused	
	2	LWL	Water Leak Sensor	
	10			
	3	HD	Unused	
	11			
	4	TH	Connect to the Display Control (Thermostat)	SELV (14V)
	12			
	5	Condensate APS	Condensate Air Pressure Switch	
	13			
	6	Flue APS	Unused	
	14			
	7	BL	Burner Limit	
	15			
	8	HL	Water High Limit	
	16			

CONNECTOR			DESCRIPTION	HT SELV
NO. OF LOCATION	PIN	BOARD SILK		
CN7 LWD1140-14	1	F.S	Flame Detect Sensor	SELV (5V)
	8			
	2	OP.S	Operating Water Temperature Sensor	
	9			
	3	DH.S	DHW Temperature Sensor	
	10			
	4	I.S	Inlet Water Temperature Sensor	
	11			
	5	BG.S	Exhaust Temperature Sensor	
	12			
	6	OT.S	Optional Temperature sensor	
	13			
	7	SP.S	Unused	
	14			
CN12 SMW250-07	1	AGM	AGM Stepper Motor Coil / Y Phase	SELV (24V)
	2		AGM Stepper Motor Coil / X Phase	
	3			
	4		GND -	
	5		AGM Stepper Motor Position	SELV (14V)
	6		VDD	SELV (24V)
	7			
CN10 SMW250-08	1	DHM (Mixing Valve)	DHM Stepper Motor Coil / Y Phase	SELV (14V)
	2		DHM Stepper Motor Coil / X Phase	
	3			
	4		GND	
	5		DHM Stepper Motor Position	
	6		Unused	
	7		VDD	
	8			
CN14 SMW250-09	1	IWC (Flow Control Valve)	GND	SELV (14V)
	2		IWC Stepper Motor Position	
	3		VDD	
	4		IWC Stepper Motor Coil X Phase	
	5		IWC Stepper Motor Coil Y Phase	
	6		VDD	
	7		IWC Stepper Motor Coil / X Phase	
	8		IWC Power IWM Stepper Motor Coil / Y Phase	
	9		Unused	-

CONNECTOR			DESCRIPTION	HT SELV
NO. OF LOCATION	PIN	BOARD SILK		
CN3 SMW250-06	1	OPB	Optional Push Button	SELV(5V)
	2			
	3		Unused	
	4	FLUX1	VCC	SELV (5V)
	5		Water Flow Sensor	
	6		GND	
CN5 SMW250-10	1	RPM	Fan RPM Check	
	2		GND	

Model	NGTH-9700C : Circuit Board	Check Point (Circuit Board)	N/A
Function	The part for controlling all components contained in the water heater.		
Failure Event	Abnormal Circuit Board operation.		
Effects	All the features of the product will not work when the circuit board is damaged or broken.		
Error Code	Er 73, Er 76, Er 78		
Diagnostic	Replace the Circuit Board.		
Color / Wire Number	N/A		

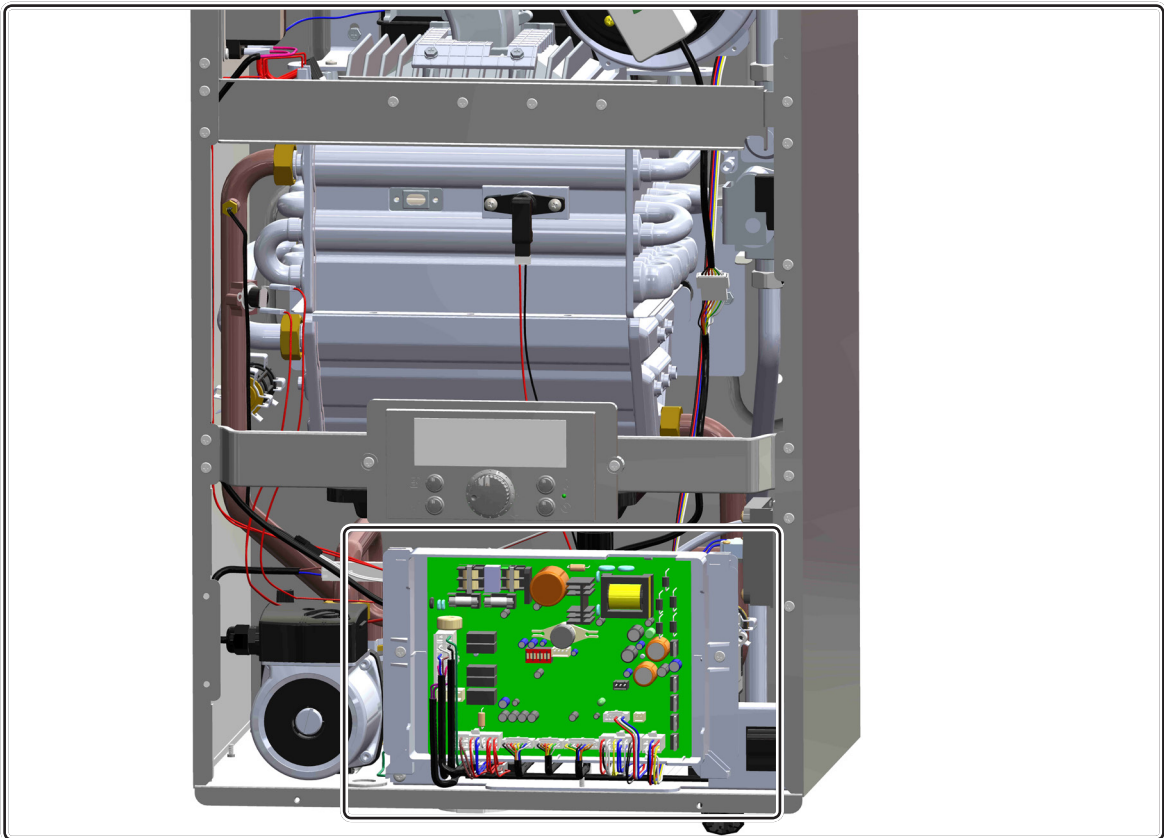

Model	GB-220/210 HB-220/210 : Temperature Thermistor	Check Point (Circuit Board)	CN7
Function	Monitors hot water temperature so that the unit can adjust or turn off the burner when the measured temperature rises above the set temperature.		
Failure Event	Sensor malFeature		
Effects	Product damage is caused.		
Error Code	Er 16, Er 31, Er 32, Er 33, Er 35, Er 94		
Diagnostic	① Check the connection around the temperature thermistors. ② Measure the resistance across the thermistor by using a multi-meter.		
Color / Wire Number	① Hot Water Outlet_GB-220 (Yellow/Yellow) : Connector ③,⑩ (Yellow/Yellow) ② DHW Inlet_HB-220 (Blue/Blue) : Connector ④,⑪ (Blue/Blue) ③ Exhaust_HB-210 (Blue/White) : Connector ⑤,⑫ (White/Blue) ④ Operating_GB-210 (Black/Black) : Connector ②,⑨ (White/White)		

NO	Item	Standard	
		Temperature	Resistance(k.Ω)
1	Temperature – Resistance Type Idling Condition	77 ± 0.2 °F	(8.520)
		25 ± 0.1 °C	
		122 ± 0.2°F	3.485 ± 3%
		50 ± 0.1 °C	
2	B Fixed Number (25/85)	185 ± 0.2°F	(1.250)
		85 ± 0.1 °C	

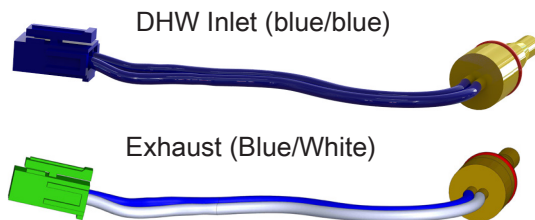

NO	Item	Standard	
		Temperature	Resistance(k.Ω)
1	Temperature – Resistance Type Idling Condition	32 ± 0.2°F	(10.99)
		0 ± 0.1 °C	
		122 ± 0.2°F	(3.906)
		50 ± 0.1 °C	
2	B Fixed Number (25/85)	185 ± 0.2°F	0.552 ± 3%
		85 ± 0.1 °C	

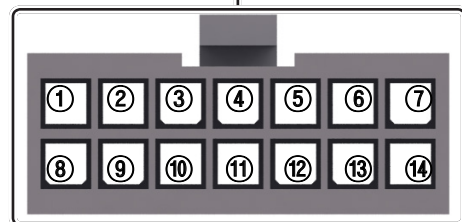
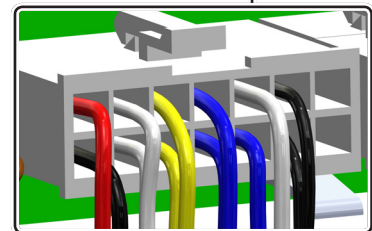
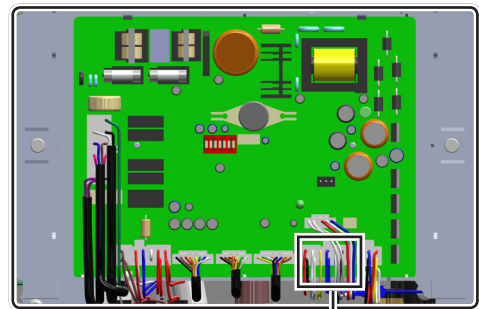
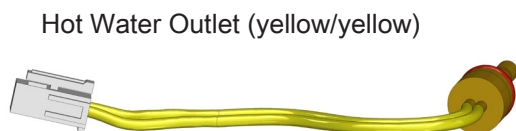

- ▶ Operating thermistor - Wire color (Black), Connector color (Black)
- ▶ Wire from PCB - Wire color (White), Connector color (Black)

Operating (Black/Black)

Model	T1-11 : Overheat Limit Switch	Check Point (Circuit Board)	CN11
Function	The part for automatically blocking the product operation when the temperature is beyond the set.		
Failure Event	Overheated water and burner temperature are not detected.		
Effects	Product damage is caused.		
Error Code	Er 20, Er 43		
Diagnostic	① Check for continuity across the Overheat Limit Switch by using a multi-meter. ② Check the Dip Switch setting. ③ Check the nozzles.		
Color / Wire Number	① Heat exchanger outlet pipe (Red/Red) : Connector ⑧, ⑯ ② Burner case (Red/Red) : Connector ⑦, ⑮		

Burner Limit Switch
(302°F/150°C)

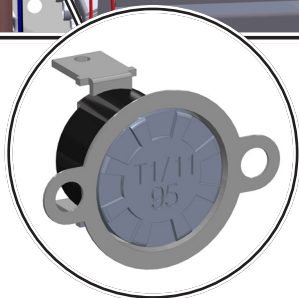
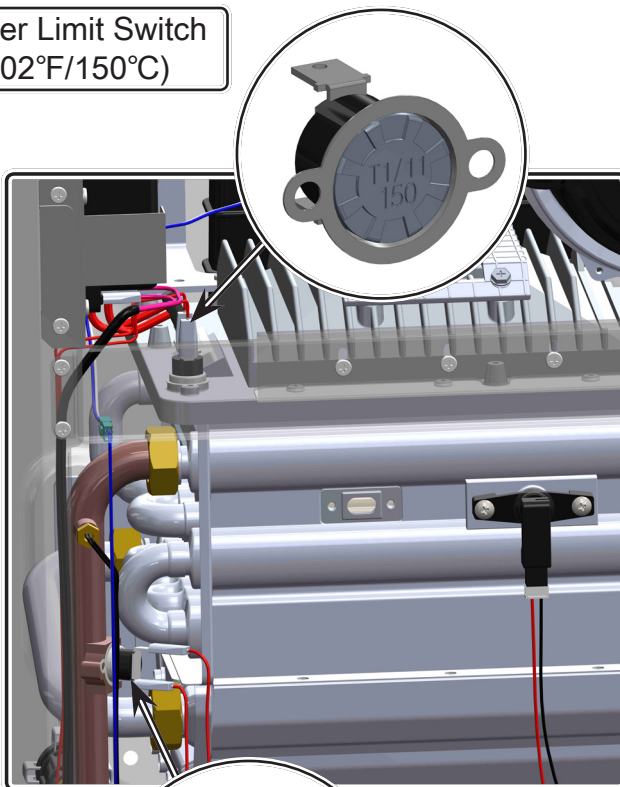

High Limit Switch
(203°F/95°C)

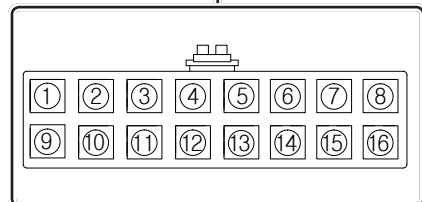
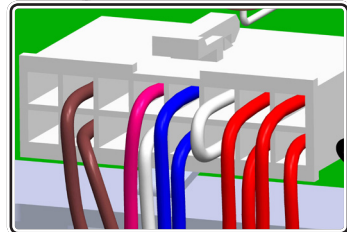
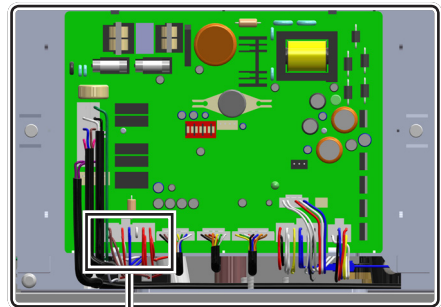

Model	Water Leakage Detector	Check Point (Circuit Board)	CN11
Function	Monitors for water leakage.If water leakage is detected, the water heater will close the water supply valve.		
Failure Event	Water leakage is not detected.		
Effects	Damage of the product is caused by the water leakage.		
Error Code	Er 45		
Diagnostic	Check the Water Leakage Detector connections.		
Color / Wire Number	Water leakage detector (Brown) : Connector ②,⑩		

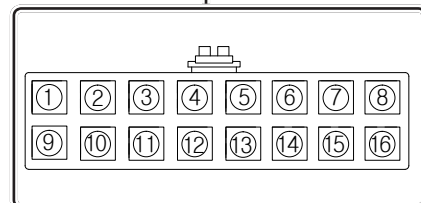
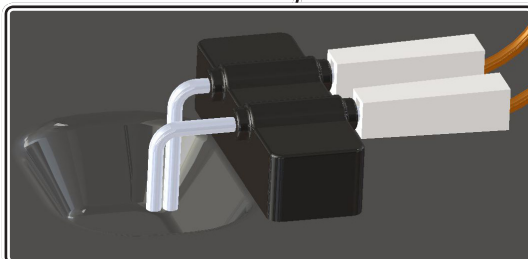
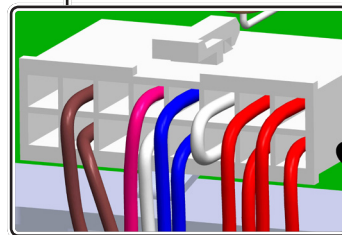
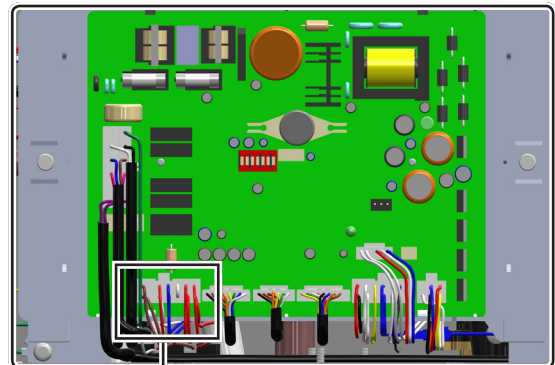
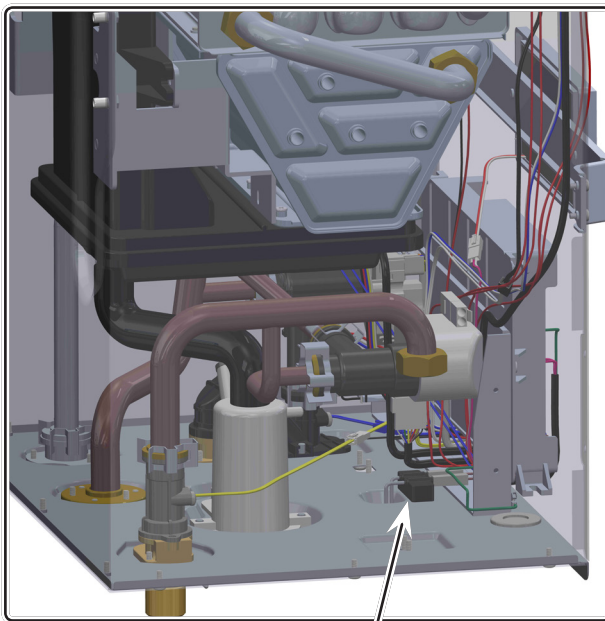

Model	Gas Leak Detection Sensor	Check Point (Circuit Board)	N/A
Function	Monitors for gas leakage. If gas leakage is detected, the water heater will power down.		
Failure Event	Gas leak detection sensor is not operated.		
Effects	Explosion risks by leaking the gas.		
Error Code	Er 40		
Diagnostic	① Check the leakage around the gas valve and connected pipes by using soapy water. ② Check the burner assembly		
Color / Wire Number	N/A		

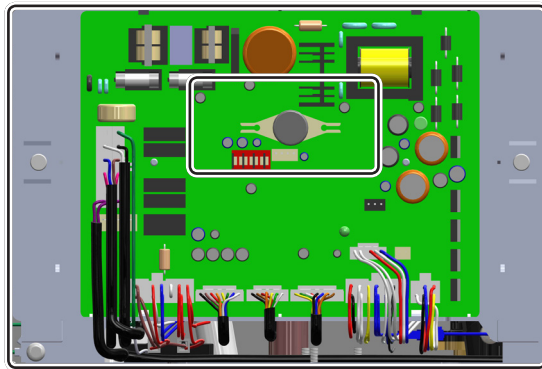
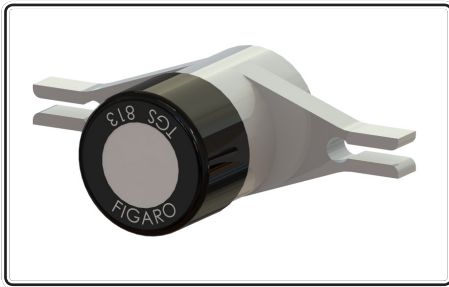

Model	SAPS 70F : Air Pressure Switch	Check Point (Circuit Board)	CN 11
Function	The part for preventing the inflow of exhaust gas, when exhaust vent and exhaust passage are blocked by condensate.		
Failure Event	① Combustion noise is generated. ② Imperfect and lifting flame occurs.		
Effects	Carbon monoxide exceeding the reference is discharged. The appliance is not working.		
Error Code	Er 29		
Diagnostic	① Check the connection around the Air Pressure Switch. ② Check the hose for blockage or bending. ③ Check the condensate passage. ④ Check voltage range of Air Pressure Switch.		
Color / Wire Number	Air pressure switch (blue/blue) : connector ⑤, ⑬		

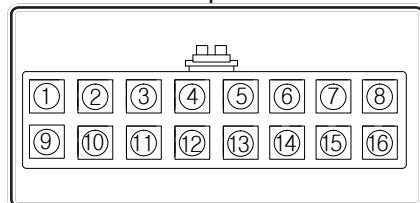
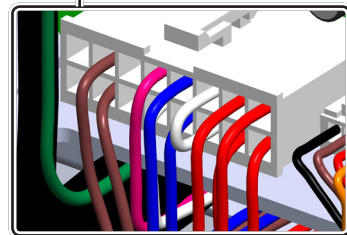
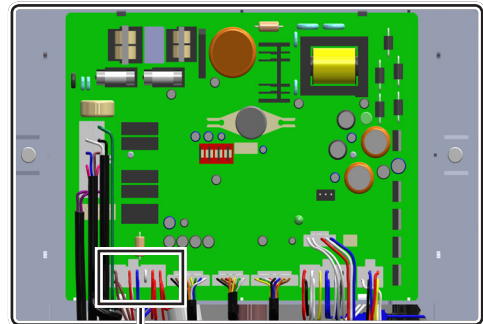
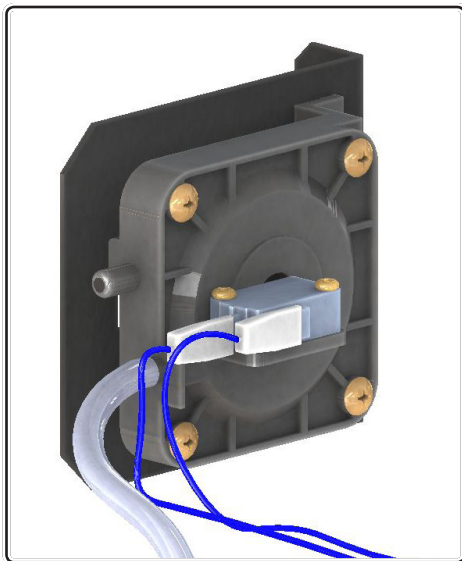

Model	T405-158R : Flow Control Valve	Check Point (Circuit Board)	CN 14
Function	The part controlling the water quantity for supplying the stable hot water by detecting the water flow rate(More than 0.5gallon) in the pipes.		
Failure Event	Water flow rate is not detected and water leakage occurs around the flow sensor.		
Effects	① Ignition sequence does not start. ② Operation of product is stopped once detecting water leakage.		
Error Code	Er 65		
Diagnostic	① Restart the product ② Check the connection around the flow sensor.		
Color / Wire Number	[IWM (Inlet Water Modulation)] GND (yellow) : connector ① IWM Stepper motor position (green) : connector② VDD (white) : connector ③ IWM Stepper motor coil X phase (red) : connector ④ IWM Stepper motor coil Y phase (black) : connector ⑤ VDD (blue) : connector ⑥ IWM Stepper motor coil /X phase (orange) : connector ⑦ IWM Stepper motor coil /Y phase(brown) : connector ⑧		

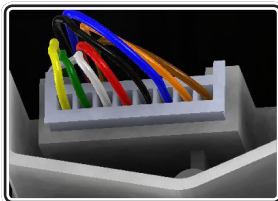
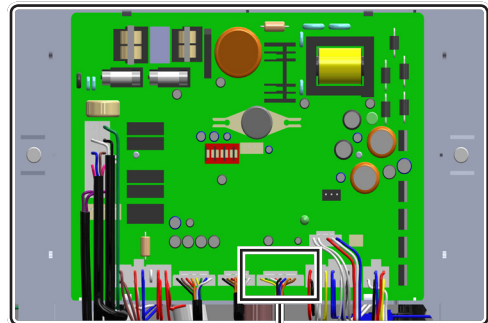
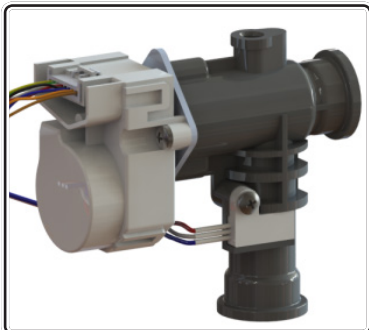

- 1. PPS material Body
- 2. Hall sensor rated voltage DC5~18V 8mA. Max
 - Minimum Flow Rate :
 - ON: 0.47gal (1.8 lpm) , OFF: 0.39 gal (1.5 lpm)
 - Maximum Operating Flow Rate : 11.1 gal (42 lpm)

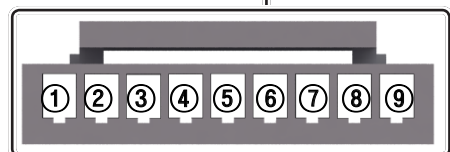
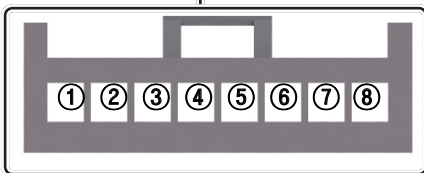
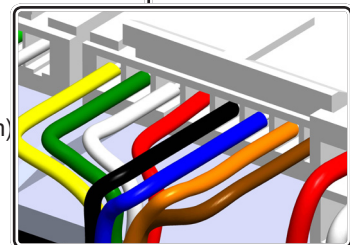

Model	Flow Sensor : 7855P-083	Check Point (Circuit Board)	CN3
Function	This sensor detects water flow (more than 0.5 GPM) through DHW loop.		
Failure Event	Water flow is not detected.		
Effects	Domestic hot water set point is not achieved.		
Error Code	N/A		
Diagnostic	<ul style="list-style-type: none"> ① Restart the appliance. ② Visual inspection : check flow sensor wiring for proper connection. ③ Visual inspection : check flow sensor for debris. 		
Color / Wire Number	<ul style="list-style-type: none"> ① Ground : Connector (blue ⑥) ② Flow Signal : Connector (white ③) ③ DC 5V : Connector (red ④) 		

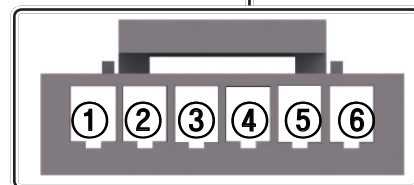
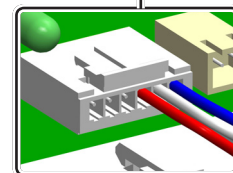
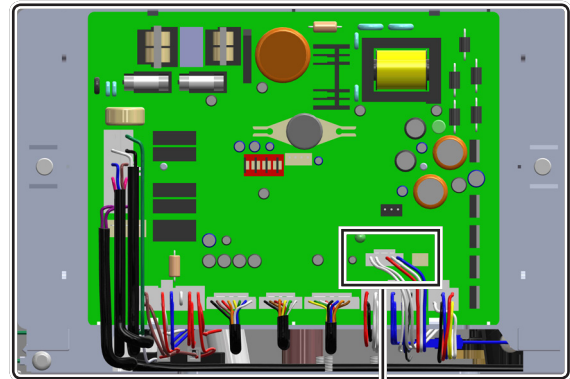
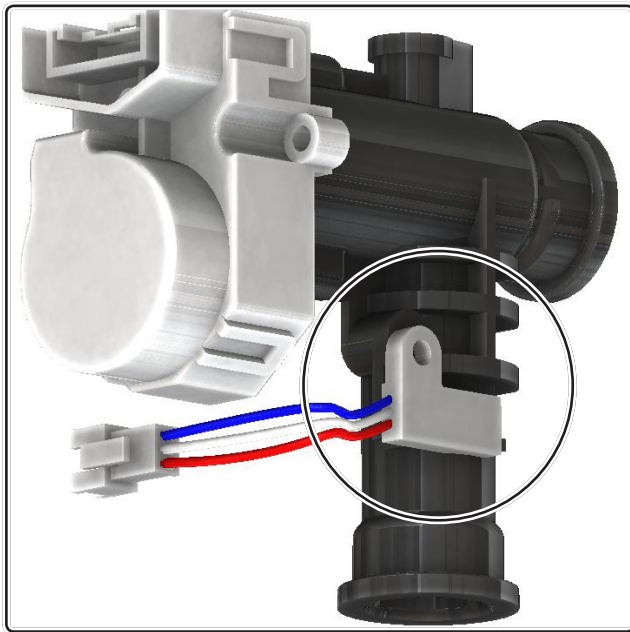

Model	KI-790U : Igniter	Check Point (Circuit Board)	CN 9
Function	The part for supplying the ignition energy to the burner by continuously discharging the high voltage.		
Failure Event	Ignition is not generated.		
Effects	Operation of product is stopped.		
Error Code	Er 10 , Er 11		
Diagnostic	① Visual inspection : Connection and/or breakage of wire. ② Check : voltage range		
Color / Wire Number	Ignition Transformer (red) : connector ④ Ignition Transformer (red) : connector ⑩		

Input voltage	Output current	Output voltage
AC 120V 60Hz	6 ± 2mA	15 ± 2kV

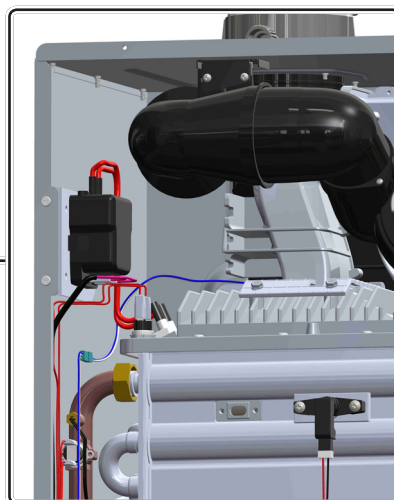
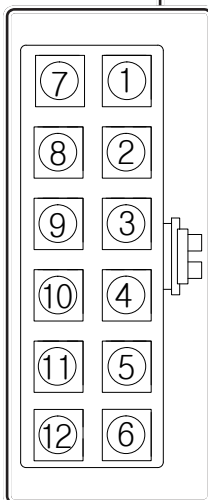
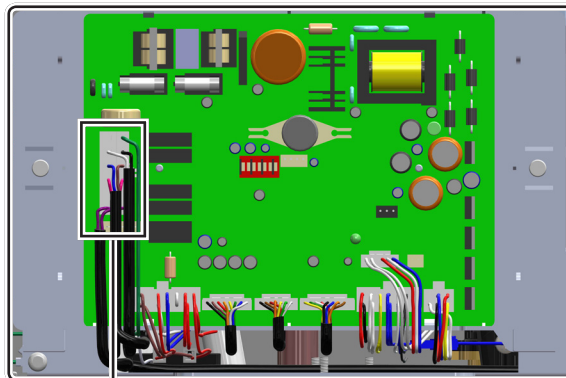
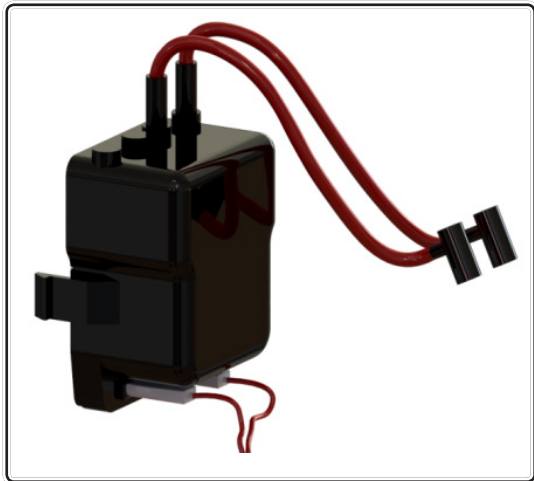

Model	RS-100 : Flame Detection Sensor	Check Point (Circuit Board)	CN 7
Function	Self-made part to indicate the normal status of burner by detecting the flame after igniting and inflowing the gas and air mixture.		
Failure Event	Ignition fault.		
Effects	Abnormal product operation.		
Error Code	Er 10, Er 11, Er 39, Er 72		
Diagnostic	① Check the discoloration of flame monitoring window. ② Check the connection around the flame detection sensor. ③ Check the flame sensor by using a multi-meter.		
Color / Wire Number	Flame Detect Sensor (black) ① : connector ⑧ Flame Detect Sensor (red) ② : connector ①		

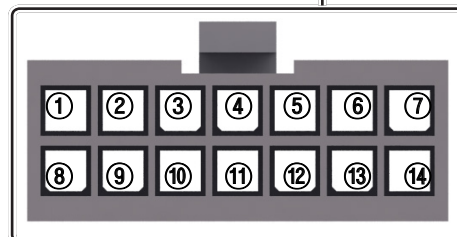
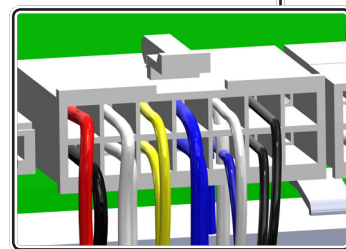
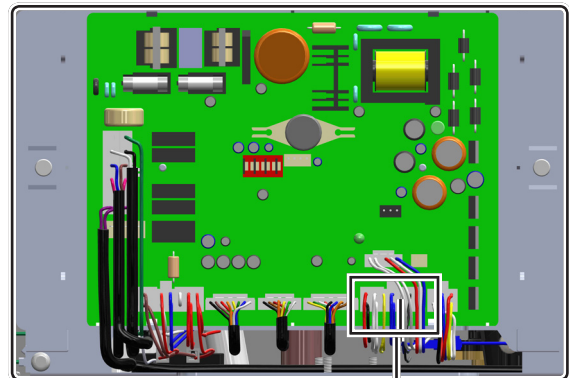
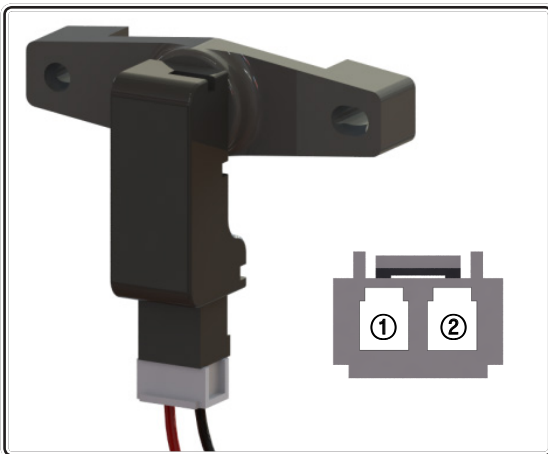

1. Electrical Characteristics
 - Maximum workable voltage :DC 35V
 - Maximum allowable current :DC 30mA
 - Maximum power dissipation :DC 80mW

2. Optical characteristics
 - Dark current : 0.05uA/ MAX (0.6uA)
[Condition: 0LX (Intensity of illumination), 10V(Voltage)]
 - Spectrum luminosity curve : 880nm (Peak Sensitivity)
 - Range of sensing : 800 ~ 1000nm
 - Flame ON: DC 2.5V or less
 - Flame OFF: More than DC 2.5V

Model	AGM : Air Gas Mixer	Check Point (Circuit Board)	CN12
Function	The part for supplying ideally the air and gas mixture to the heat exchanger.		
Failure Event	① Imperfect combustion occurs. ② lifting flame occurs.		
Effects	① Abnormal product operation. ② Carbon monoxide exceeding the reference is discharged.		
Error Code	Er 67		
Diagnostic	① Restart the water heater. ② Check the connection. ③ Check the fan intake.		
Color / Wire Number	Air Gas Mixer (black) : ① connector (AGM / Y Phase) Air Gas Mixer (brown) : ② connector (AGM Y Phase) Air Gas Mixer (red) : ③ connector (AGM / X Phase) Air Gas Mixer (orange): ④ connector (AGM X Phase) Air Gas Mixer (yellow) : ⑤ connector (GND) Air Gas Mixer (green) : ⑥ connector (AGM Position Sensor) Air Gas Mixer (white) : ⑦ connector (DC 24V)		

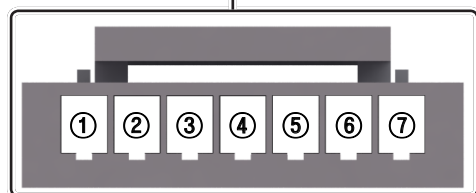
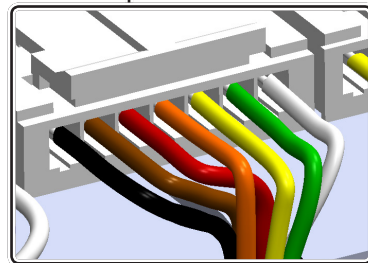
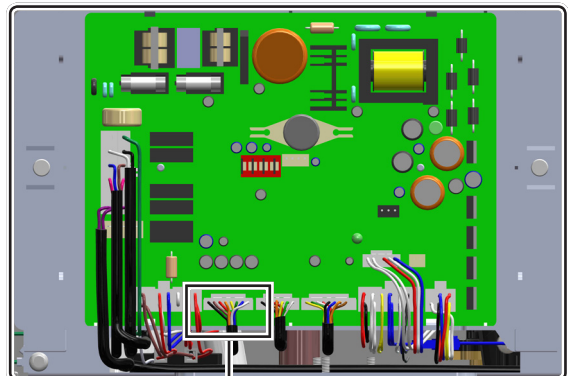
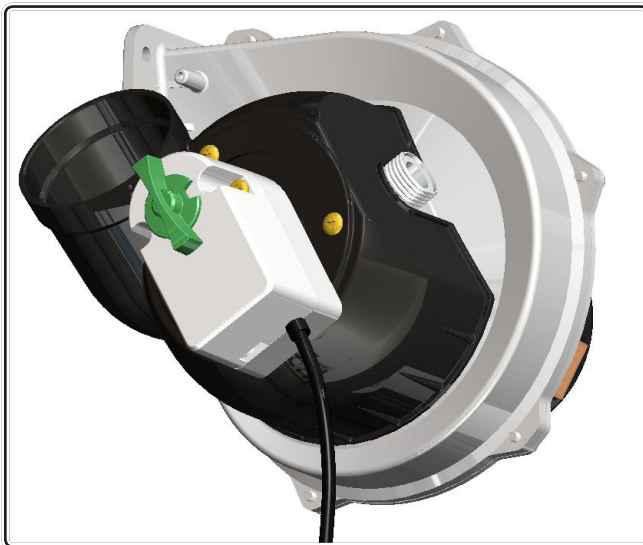

1. Operating Temperature : 0~60 °C
2. Using the gas pressure : 0.725 PSI (5 kPa)
3. Maximum amount of gas : 194 ft³/hr (5.5 m³/hr) (NG)
4. T/D(Turn/Down ratio) : 10:1(180,000Btu) ,11:1(199,000Btu)
5. Motor Specification
 - Type : Stepping Motor
 - Phase : 4 Phase
 - Drive type : Unipolar Drive / V-Constant
 - Supply Power : < 24 VDC (Non-continuous operation)
 - Phase excitation system : 2-2
 - Step angle : 7.5 deg(2-2Phase), (1-2 Phase : 3.75 deg)
 - Direction of rotation : CW / CCW (Bidirectional)
 - Reduction ratio : 1 / 60

Model	VK4115V1022 : Gas Valve	Check Point (Circuit Board)	CN9
Function	The part for controlling electrically the supplied gas volume and for performing optimally the combustion.		
Failure Event	① Gas leakage occurs. ② Gas valve is not operated. (Unable to open/close) ③ Gas flow is not modulated. (Proportional gas valve)		
Effects	① Gas leakage from the water heater. ② Spark is not generated.. ③ Operation of product is stopped. ④ Carbon monoxide exceeding the reference is discharged.		
Error Code	Er 11, Er 40		
Diagnostic	① Check the connection and breakage of gas valve. ② Check the connection and mounting location. ③ Check the flue of water heater. ④ Check range of voltage.		
Color / Wire Number	Gas Valve (purple/purple) : connector ⑥, ⑫		

1. Backpressure
 : 1st valve: 0.725 PSI (5 kPa)
 : 2nd valve: 0.145 PSI (1 kPa)
2. Ambient temperature:
 : 5 ~ 158°F (-15°C ~ 70°C)
3. Max inlet pressure: 0.87 PSI (6 kPa)
4. Operating Ratings: AC 120V / 60Hz
 * Between terminal below.

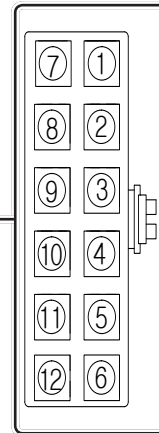
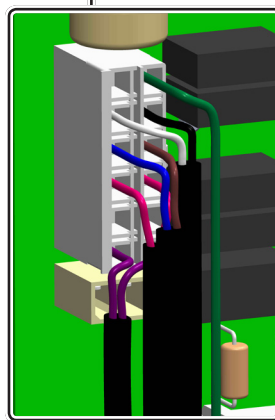
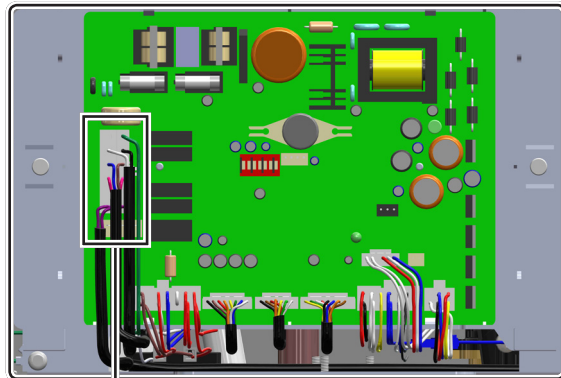
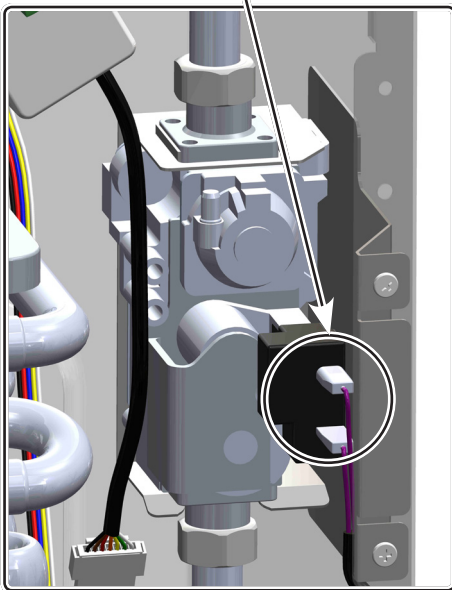

Model	KBP-126H : Fan	Check Point (Circuit Board)	CN4
Function	The part for supplying the air and gas into the burner required for the combustion.		
Failure Event	① Abnormal noise occurs at the fan. ② Abnormal fan speed(RPM). ③ Poor connection.		
Effects	① Abnormal combustion. ② Abnormal noise occurs. ③ Improper or no operation of water heater.		
Error Code	Er 41, Er 61		
Diagnostic	① Check the clogging of the vents. ② Check status of the connection. ③ Check range of voltage.		
Color / Wire Number	[BLDC FAN] Fan Start Coil (white) ④ : connector ④ RPM Sensor (yellow) ⑥ : connector ⑥ GND (blue) ② : connector ② VDD (red) ③ : connector ③ Fan End Coil (black) ⑤ : connector ⑤		

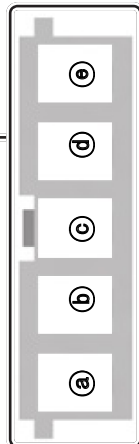
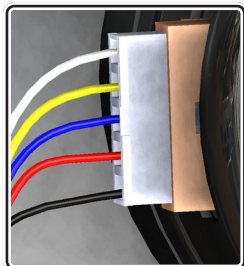
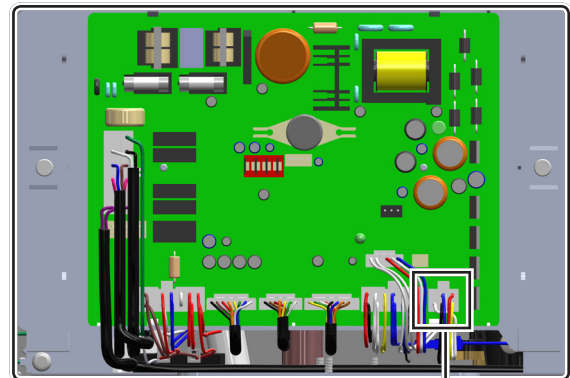

1. Rated Specifications

- Motor type : DC BRUSHLESS MOTOR
- Rated Voltage : $V_s = 28V / V_c = DC 12V$
- Working Voltage : $V_s = DC 28V / V_c = DC 12V$
- Rated Current : 2A
- Speed Control : PWM

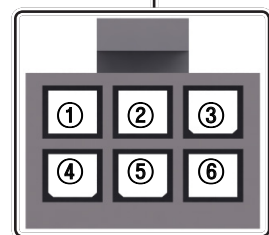
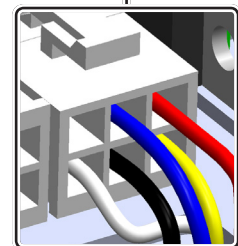

Model	Metal Fiber Premix Burner	Check Point (Circuit Board)	N/A
Function	The part supplying the heat source by mixing and combusting the air and gas.		
Failure Event	<ul style="list-style-type: none"> ① Unable to initialize/sustain combustion. ② Soot occurs on the surface of burner. ③ Gas leakage occurs from burner. 		
Effects	<ul style="list-style-type: none"> ① Abnormal combustion. ② Unstable flame generation. ③ Ignition failure. 		
Error Code	N/A		
Diagnostic	Check the debris on the burner surface and unstable flame.		
Color / Wire Number	N/A		

The design of the Premix Burner significantly reduces the amount of emitted carbon monoxide (CO), nitrous oxides (NOx), and other harmful flue gas components by regulating the air-fuel ratio unlike a typical Bunsen burner.

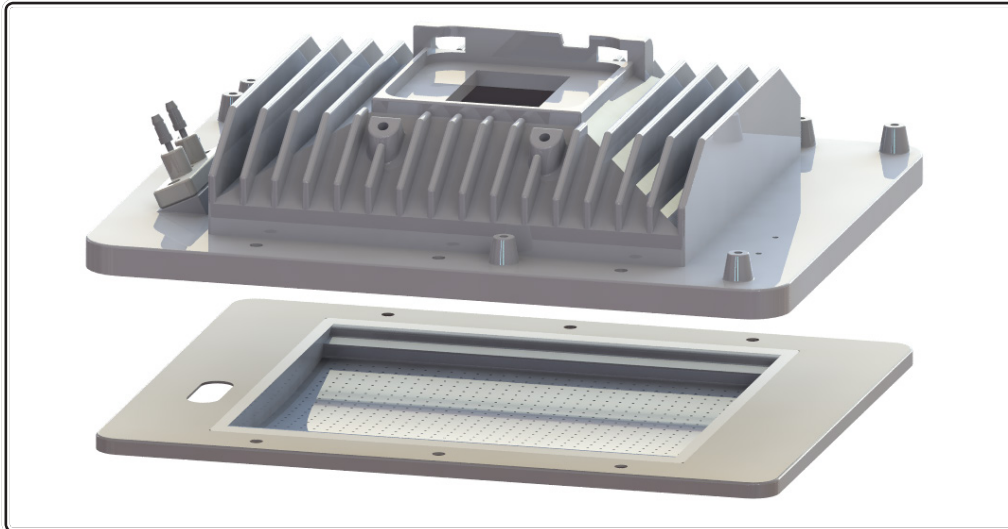

Model	SFCV-KR : Water Mixing Valve	Check Point (Main PCB)	CN 10
Function	The part for controlling the temperature of hot water by mixing the cold and hot water in order to prevent the burns and supply the constant temperature of hot water.		
Failure Event	① Water leakage occurs around the water mixing valve. ② Abnormal valve operation.		
Effects	① Operation of product is stopped once detecting water leakage. ② The temperature of hot water is not constant.		
Error Code	Er 16, Er 66		
Diagonostic	① Restart the product. ② Check the connection around the water mixing valve. ③ Check range of voltage.		
Color / Wire Number	[Water Mixing Valve] DHM Y Phase (black) : connector ① DHM Y Phase (brown) : connector ② DHM X Phase (red) : connector ③ DHM X Phase (orange) : connector ④ GND (yellow) : connector ⑤ DHM Position sensor (green) : connector ⑥ Flow2 sensor (blue) : connector ⑦ DC 14V (white) : connector ⑧		

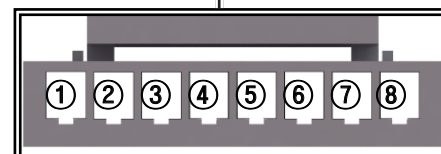
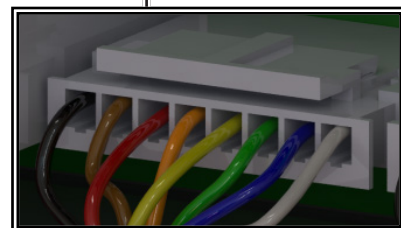
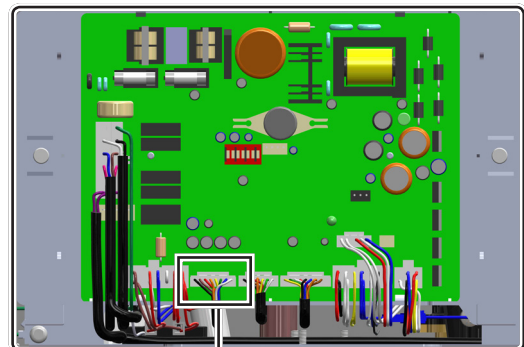
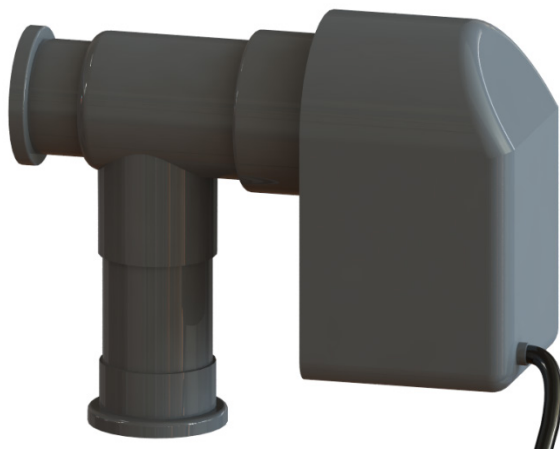

1. Cold water and hot water mixed
2. Step Control Motor Applied.
3. Operating Fluid : 0°C~80°C (32 ~ 176°F)
4. Operating Pressure: 0~0.98Mpa
5. Supply Voltage : DC24V
6. PPS material Body
7. DHM : Domestic Hot Water Mixing Modulation

Model	GPD15-5S: Circulation Pump	Check Point (Circuit Board)	CN9
Function	Provides circulation through the heat exchanger.		
Failure Event	Water flow is not detected.		
Effects	① Unit does not operate. ② Circulation pump is not operating.		
Error Code	Er 44, Er 60		
Diagnostic	① Visual inspection : check wiring for proper connection. ② Check supply voltage.		
Color / Wire Number	Internal CH primary circulation pump : Connector (blue ⑨, brown ⑩)		

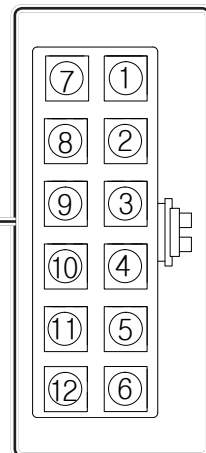
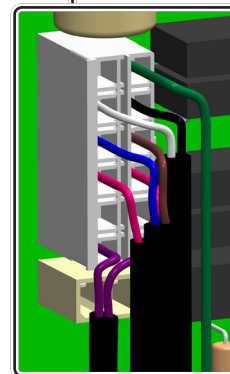
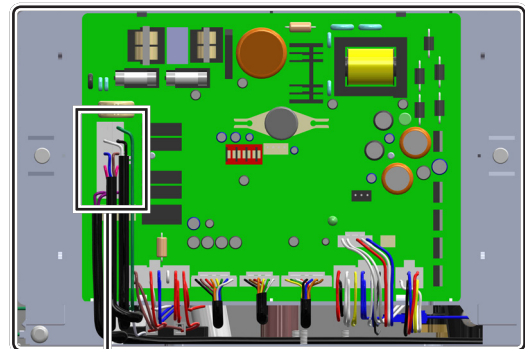
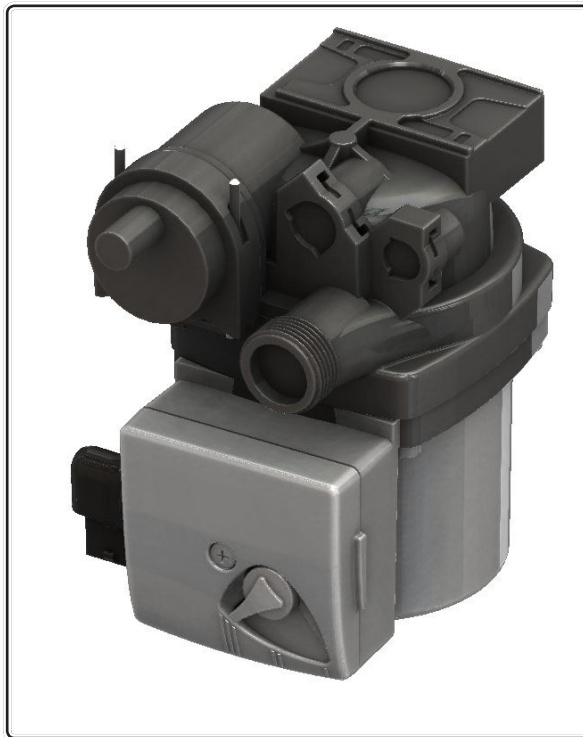

Model	DHW Inlet Filter	Check Point (Circuit Board)	N/A
Function	The part consists of durable STS, PPS material for filtering out debris and heavy metals.		
Failure Event	Input capacity of cold water is not constant and thermal efficiency is poor.		
Effects	Noise at the heat exchanger is generated and pipes are blocked by the debris.		
Error Code	N/A		
Diagnostic	Clean the DHW Inlet filter.		
Color / Wire Number	N/A		

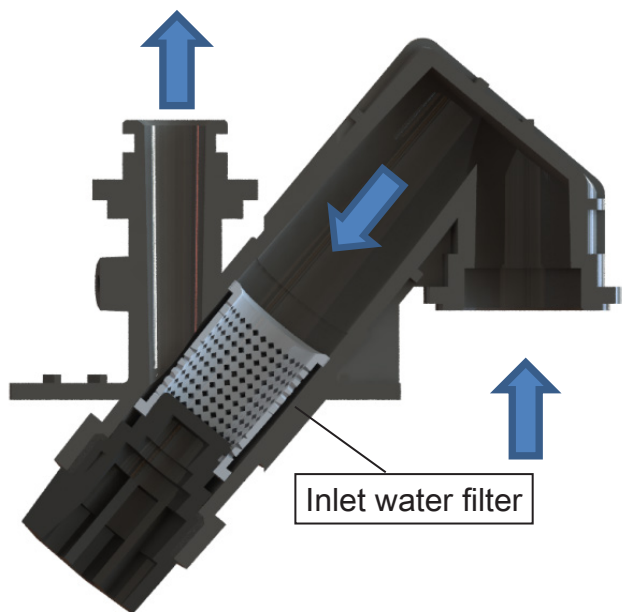
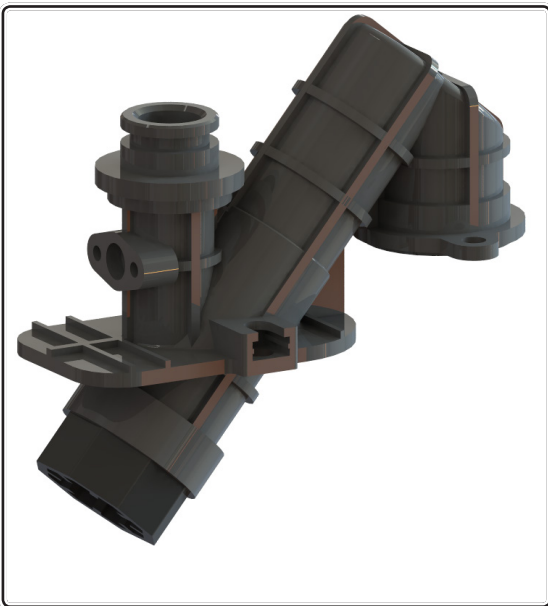

Model	Heat Exchanger(STS)	Check Point (Circuit Board)	N/A
Function	The part for heating the hot water by Absorbing the high-temperature heat generated at the burner.		
Failure Event	① Water or exhaust gas leakage. ② Abnormal heat exchange.		
Effects	① Operation of product is stopped. ② Exhaust gas leakage. ③ Abnormal noise occurs.		
Error Code	Er 20, Er 33, Er 43, Er 94		
Diagnostic	Check the heat exchanger surface for cracks or leaks.		
Color / Wire Number	N/A		

1. Heat exchange method : Instantaneous
2. Material : SUS
3. Construction : SUS brazing

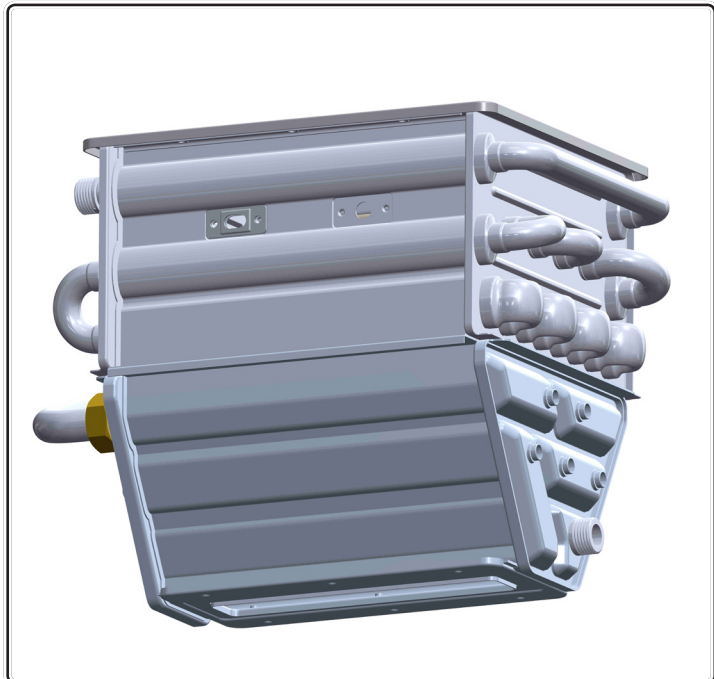

Model	Siphon : Condensate Trap	Check Point (Circuit Board)	N/A
Function	The part for reliably discharging the condensate generated by the combustion.		
Failure Event	Condensate fails to drain freely and backs up in the exhaust line.		
Effects	1. Product corrosion and degradation due to excessive condensate buildup. 2. Blockage of air flow.		
Error Code	Er 29		
Diagnostic	Check the hose for blockage or bending.		
Color / Wire Number	N/A		

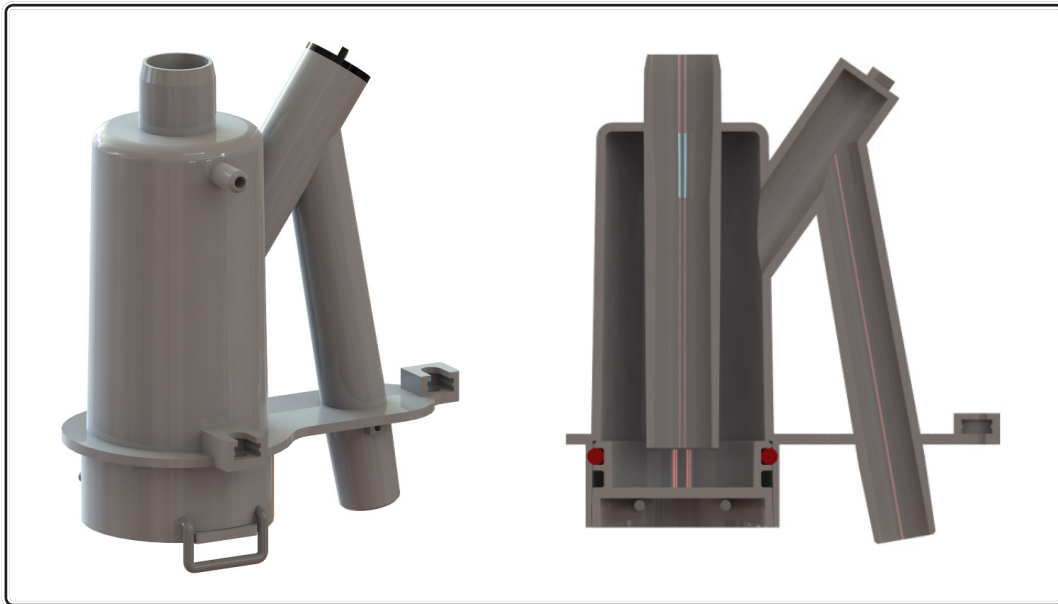

A. CONTROL PANEL

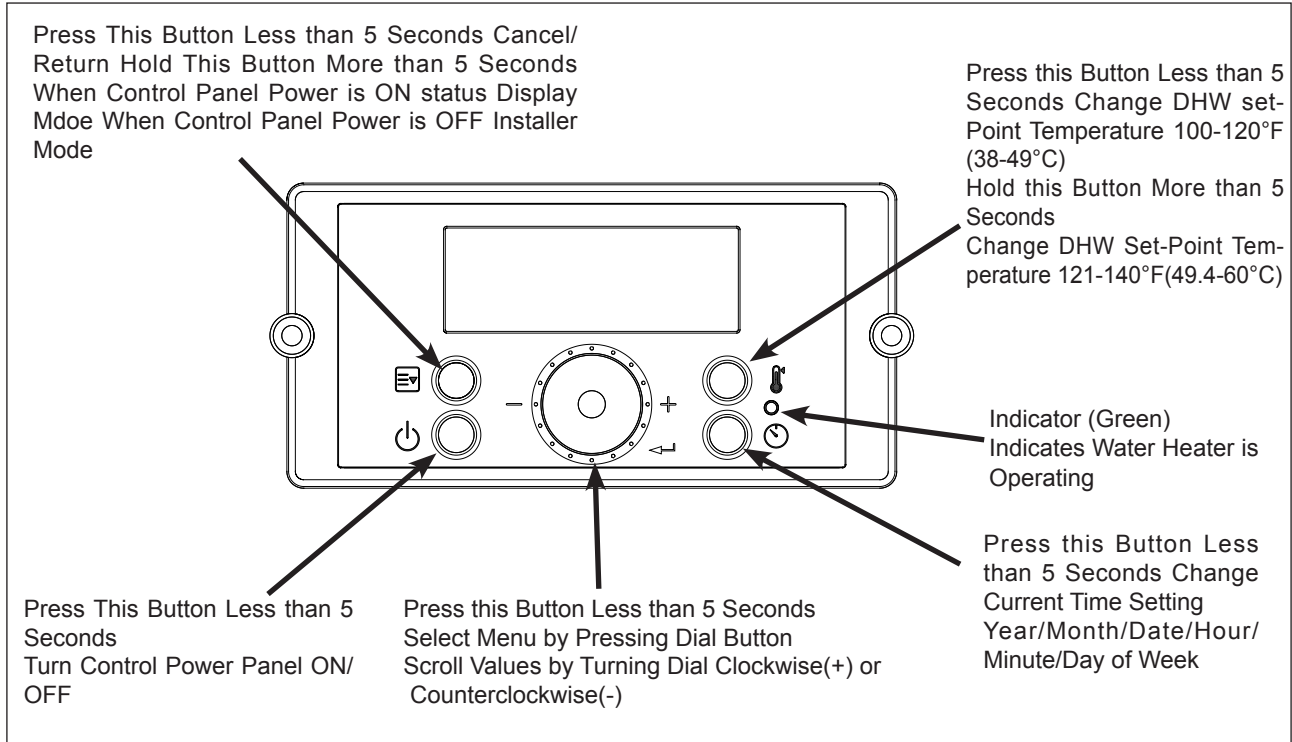

Figure 32 – Water Heater Control Panel Detail

- B. LCD DISPLAY DESCRIPTIONS

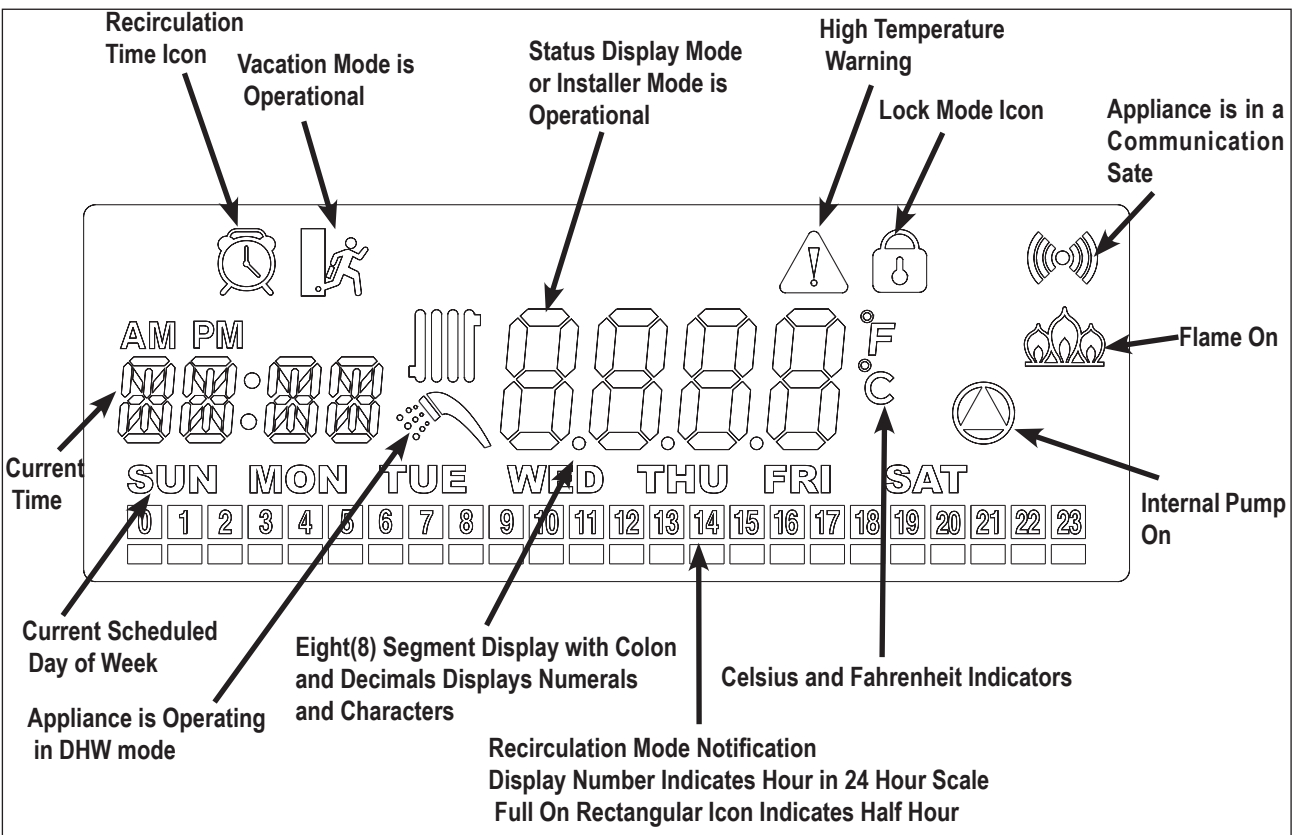

Figure 33 – LCD Display Detail

LCD also features a backlit lamp that will illuminate:

- When a user action is detected (a button is pressed)
- The display will turn off after approximately 20 seconds if no buttons are pressed

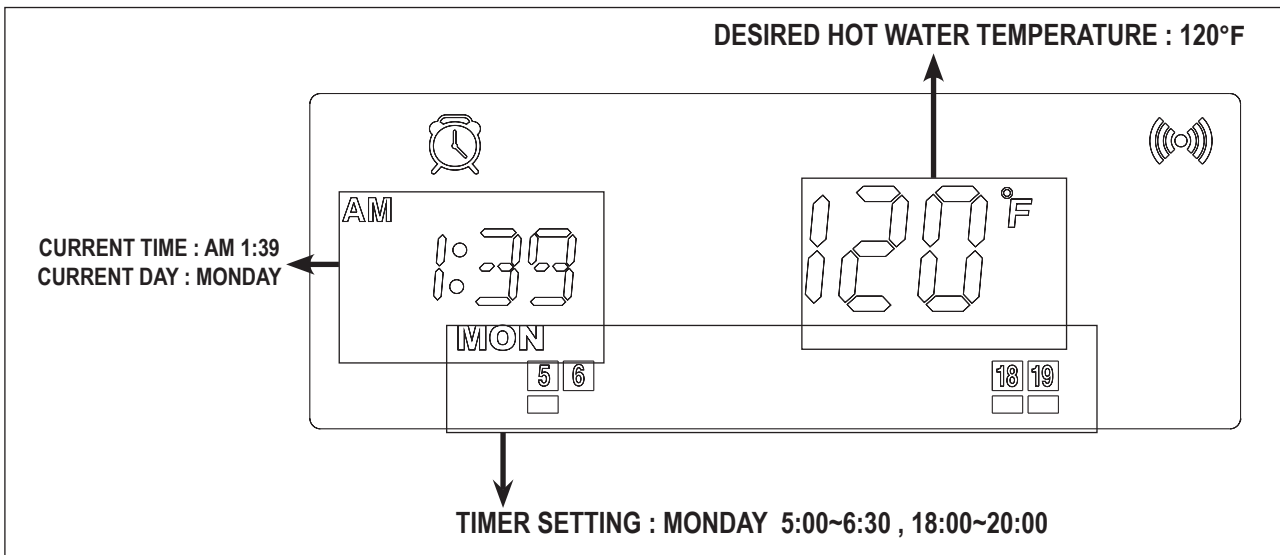

Figure 34 – Example Display

▪ **C. START-UP SEQUENCE**

After the appliance is powered ON, the LCD display shows a sequence of information. The icons will flash, followed by various indicators that describe the appliance controller and software versions. It will take the appliance roughly 15 seconds to cycle through the Start-Up Sequence.

Display Items	Time for Display	Remarks
LCD Test	1 Sec	All segments "ON"
	0.5 Sec	All segments "OFF"
Category: 199	1 Sec	Pdn
	1 Sec	0061
Software Version for Front Panel	1 Sec	SPn
	1 Sec	00.XX
Software Version for Water Heater	1 Sec	SFn
	1 Sec	XX.XX
Hardware Version for Water Heater	1 Sec	Hdn
	1 Sec	00XX

Table 24 – Start-Up Sequence

The Control System can operate through user and service modes that have specific LCD outputs and dedicated controls, including:

- Changing the Set-Point Temperature
- Error Mode
- Status Display Mode
- Installer Mode
- High Elevation Mode
- High Temperature Mode

NOTE: The Control System will not allow changes if Lock Mode is activated unless the  button is pressed for more than 5 seconds.

▪ **D. CHANGING THE DHW SET-POINT**

NOTE: The setpoint cannot be changed if water is flowing through the unit. Ensure there is no demand on the water heater when changing setpoint. The display shows the  icon when the DHW set-point can be changed

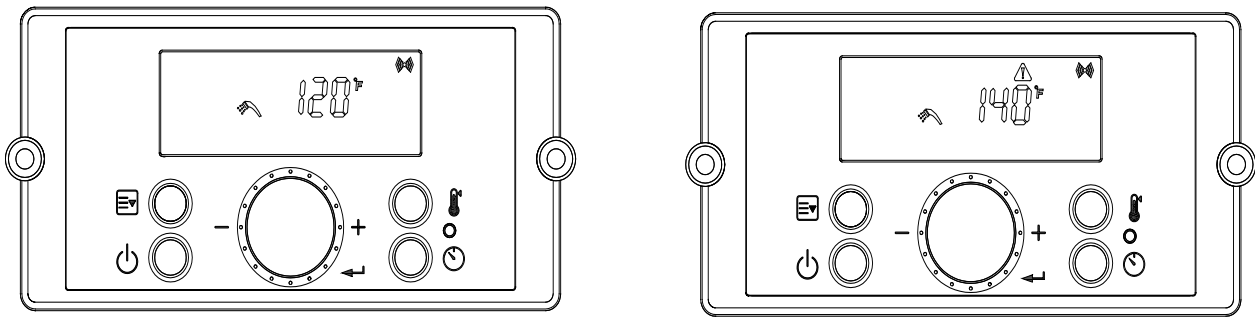

Figure 35 – DHW Set-Point Screens

Press the button when the display panel is powered ON to change the DHW Set-Point. The DHW icon and current set-point will display and flash. This indicates that the DHW Set-Point can be changed. Factory DHW Set-Point is 120°F(49°C). Initial DHW Set-Point range is 100 – 140°F (38 – 60°C).

The recommended starting temperature is 120 °F (49°C).

Turn the dial counterclockwise to lower and clockwise to raise the DHW set-point. After changing the temperature, press the button to save the set-point.

To change the DHW Set-Point above 121°F (49.5°C), press and hold the button when the display panel is powered ON.

The current DHW set-point will display. The DHW icon will flash. Then press and hold the button for five seconds. The scald warning icon (High Temperature Warning icon) will display. High temperature DHW Set-Point range is 125°F – 140°F (52°C – 60°C).

Turn the dial counterclockwise to lower and clockwise to raise the DHW set-point. After changing the temperature, press the button to save the set-point.

⚠ DANGER

Hotter water increases the risk of scald injury. Scalding may occur within 5 seconds at a setting of 140°F (60°C). Water temperature over 125°F can instantly cause severe burns, or death, from scalds. Children, disabled, and elderly are at the highest risk of being scalded. See instruction manual before setting temperature at appliance. Feel water before bathing or showering!

APPROXIMATE TIME / TEMPERATURE RELATIONSHIPS IN SCALDS	
120°F	More than 5 minutes
125°F	1 ½ to 2 minutes
130°F	About 30 seconds
135°F	About 10 seconds
140°F	Less than 5 seconds
145°F	Less than 3 seconds
150°F	About 1 ½ seconds
155°F	About 1 second

E. STATUS DISPLAY MODE

Status Display Mode will activate when power button is pressed and held for five seconds when the display panel is turned on at Standby Mode.

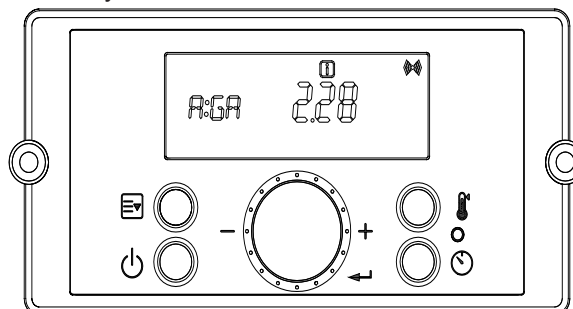









Figure 36 – Status Mode Screens

Parameter	Detail	Description
A:Li or GA	Flow Unit	Current Flow Unit (Li: Liters/min, GA: Gallons/min)
b:Fr	Fan Speed (RPM)	Current Fan Speed RPM Value
C:Lc	Lock Mode	Lock Mode is In Use (ON) or Unused (OFF) Allows user to lock out any temperature change.
d:Op	Operating Temperature	Current Heat Exchanger Operating Temperature
E:dH	DHW Outlet Temperature	Current DHW Outlet Temperature
F:Eh	Exhaust Temperature	Current Exhaust Temperature
H:In	Inlet Water Temperature	Current Inlet Water Temperature
I:rt	PH	Power On Time Power On Time: 1,000 hour increments
	rH	Burner Operating Time Burner Operating Time: 1,000 hour increments
	bnCY	Burner Cycles Burner Cycles: 1,000 times unit displayed
	PPHr	Pump Running Time 1,000 hour increments
J:AG	AGM	Adjusts AGM Position: + / - 50
K:TA	Time Adjustment	Current Clock Setting

Table 25 – Status Mode Display Screen Descriptions – NOTE: Shaded Parameters Not Used on This Software Version

Turn the dial  counterclockwise and clockwise to scroll through the displayed parameters. To view parameter details, press the  button at the appropriate screen. Press the  or  buttons to leave the parameter.



Press the  button again to return to Operation Mode.

To turn on Lock Mode, press the  button at the C: Lc parameter. Turn the dial  counterclockwise and clockwise to scroll On or Off. Press the  button to save the selection and return to the parameters.

Press the  button again to return to Operation Mode.

NOTE: The Control System will not allow the changes if Lock Mode is activated. Lock Mode will have to be turned off before making further changes

• F. CHANGING THE TIME

Press and hold the  button for five seconds when the display panel is powered ON to enter Status Display Mode. Turn the dial  counterclockwise and clockwise to scroll through the displayed parameters to parameter K:TA Press the  button to enter and change the time. The time can be adjusted as follows: Year / Month / Date / Hour / Minute / Day of Week.

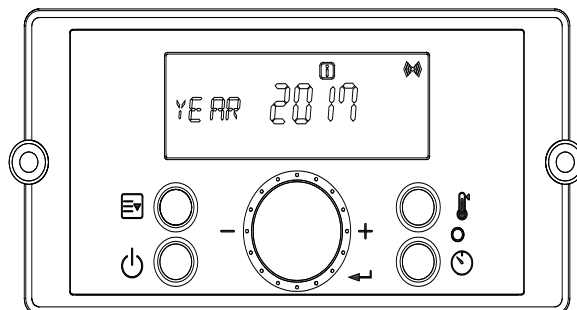





Figure 37 – Changing the Time Screen

Turn the dial  counterclockwise to lower and clockwise to raise the current time setting. After changing the setting, press the  button to save it. The next adjustable setting will appear. After the time settings have been entered, press the  button to save and return to the Status Display screens.

G. INSTALLER MODE

Installer Mode will activate when button  is pressed and held for five seconds while the water heater display is powered Off.

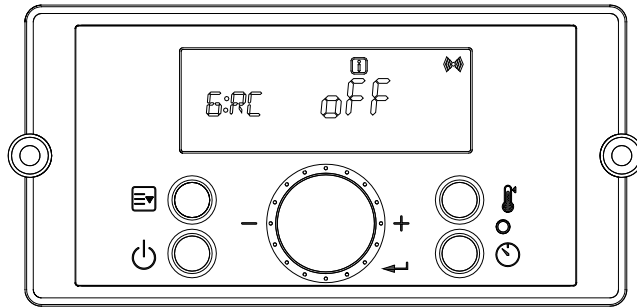



Figure 38– Installer Mode Screens

Index	Default	Parameter	Description
1:EH	N/A	Error History	Allows the Installer to View the Unit Error History Range: E0:XX – E9:XX
2:CE		Clear Error & System initialize	EHIS :Error History
			rH : Burn Hour
			bnCY : Burn Cycle
			PPHr : Pump Running Time
3:FC	GA	Unit	Use to choose unit (Water flow rate, Temperature) Lit °C : Liter/minute, Celsius GAL °F : Gallon/minute, Fahrenheit
4:FH	00	Maximum Fan Speed	Adjusts Maximum Fan Speed Range: -30 - +30
5:FL	00	Minimum Fan Speed	Adjusts Minimum Fan Speed Range: -30 +30
6:RC	oFF	Recirculation Pump Operation	Turns the Recirculation Pump On and Off Range: On – Pump On, oFF – Pump Off
7:RM	ltnL	Recirculation Mode	NOTE: 6:RC must be set to On to select 7:RM Sets the Recirculation Mode Range: ltnL – Internal Recirculation EtnL – External Recirculation / On Demand Kit, tt24 – Tilte 24 Mode, bYPS-Cross over
8:RT	HI-2	Recirculation Temperature	Sets Recirculation Temperature Range: LO – Low Temperature, HI-1 – Middle Temperature, HI-2 – High Temperature
9:HT	HI-2	Hot Water Temperature	Sets Hot Water Temperature Range: LO – Low Temperature, HI-1 – Middle Temperature, HI-2 – High Temperature
10:IV	6	Prevent Ignition	Temporarily disables the water heater from igniting for a set period of time. Range: 0 – 20 Minutes
11:HA	0 - 2	High Elevation Mode	This water heater may be installed at elevations up to 10,000 feet and operate on either Natural or LP. The appliance will de-rate by 4% for each 1,000 feet above sea level. Select the appropriate installation location as described below. Selects Installation Location for Proper Water Heater Operation at Altitude: 0-2 for installation locations from sea level to 2,000 feet 2-5 for locations from 2,000 to 5,000 feet 5-8 for locations from 5,000 to 8,000 feet Default: 0 – 2 NOTE: Use a combustion analyzer to ensure CO and CO ₂ are within the ranges shown in this manual. Adjust the offset screw in the clockwise (positive) or counterclockwise (negative) directions (approximately 1/8 turn) if the measured CO ₂ value on LOW FIRE is out of range.

Index	Default	Parameter	Description
12:Cn	oFF	Cascade	Enables Cascade Mode on the water heater. Range: on – Cascade is used, oFF – Cascade is not used
13:Eh	on	Common Vent	NOTE: 12:Cn must be set to On to select 13:Eh Enables Common Venting on the water heater. Range: on – Common Venting is used, oFF – Common Venting is not used
14:T1	oFF	Test Mode 1	Used to test the water heater when operating in Internal Recirculation Mode only. The water heater may operate while Test Mode 2 is operating. Range: on, oFF
15:T2	oFF	Test Mode 2	Used to purge air from the water heating system with an external recirculation pump. The water heater does not need to operate while Test Mode 2 is operating. Range: on, oFF

Table 26 – Installer Mode Descriptions

Toggle through displayed items by turning the dial . To change an item, press the Dial button .

Displayed items can be changed by turning the dial  counterclockwise to lower, and clockwise to raise, the displayed value.

To save settings, press the Dial button  again.

To leave Installer Mode, press button  again. The water heater will return to power off mode.

▪ H. USING RECIRCULATION MODES – STEP 1



The following section explains and details the use of the Internal / External Recirculation Modes.

Preheat or Internal Recirculation Modes – When calls for hot water are satisfied, the water heater is factory programmed to Preheat and automatically maintain the temperature set point of the water heater – 24 hours a day, 7 days a week. The differential setting can be adjusted to control the temperature set point.

Internal Recirculation Mode allows the installer to program specific recirculation functions by day and time to circulate and heat water more efficiently - when the user most needs hot water. See Recirculation Functions, this manual, for details.

External Recirculation Mode – This mode keeps an external recirculation loop warm to make hot water production more efficient and also aid in freeze protection. An external recirculation line must be installed in order to recirculate water externally. The installer may program specific recirculation functions by day and time to circulate and heat water when the user most needs hot water. See Recirculation Functions, this manual, for details.

To set Recirculation Modes:

1. Installer Mode will activate when  is pressed and held for five seconds while the water heater display is powered Off.
2. Turn the dial to 6:RC. Press the Dial button . “oFF” will flash when the 6:RC setting is ready to be changed.
3. Turn the dial to “oFF” to turn off the Recirculation Pump, or “on” to turn the Recirculation Pump on. Press the dial button  to select the setting and return to the Installer Mode.

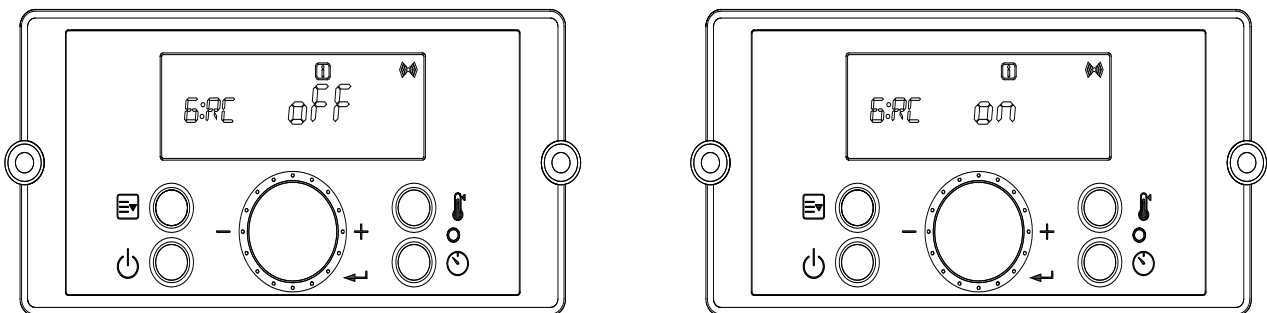

Figure 39 –6:RC - Recirculation Pump Operation

4. Next, turn the dial to 7:RM. Press the Dial button. "ltnL" will flash when the 7:RM setting is ready to be changed.
5. Turn the dial to "ltnl" to turn on Internal Recirculation Mode, or "Etnl" to use External Recirculation, or "tt24" to use Title 24 application, or "bYPS" to use Bypass Valve. Press the dial button to select the setting and return to the installer Mode. NOTE: 7:RM can only be selected after 6:RC has been turned on.

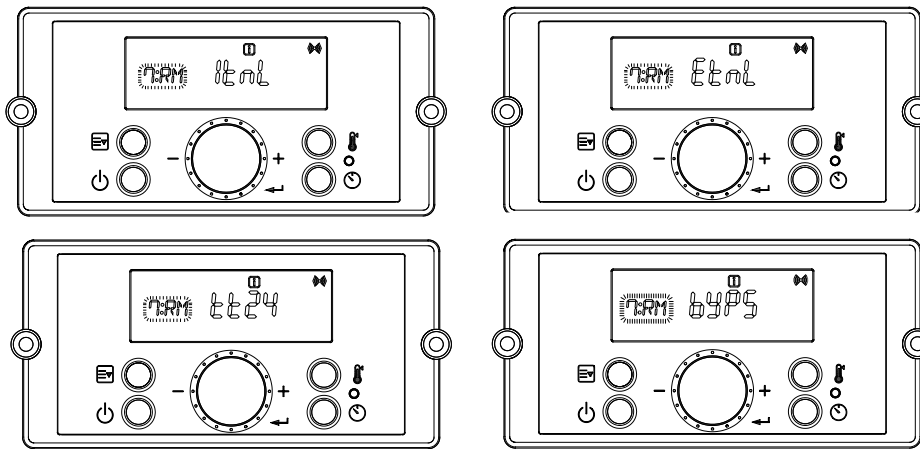

Figure 40 – 7:RM – Recirculation Mode

Setting	Detail	Description
ltnL	Preheat or Internal Recirculation Mode	Turns on Internal Recirculation
Etnl	External Recirculation Mode or On Demand Application	Turns on External Recirculation
tt24	Comply with Title 24 Regulation	Turns on External Recirculation
bYPS	Applied with Crossover valve included	Turn on Internal Recirculation

Table 27 – Internal / External Recirculation Mode Overview

6. When finished, press to exit this menu and turn power back on. Proceed to Step 2 to program the recirculation functions.

I. SETTING THE RECIRCULATION TIMER – USING RECIRCULATION MODES – STEP 2

NOTICE

Before setting the Recirculation Timer, go into the Installer Mode and change 6:RC from “off” to “on”. Recirculation Mode will not work if it is not activated in Installer Mode. See Table 28 for Recirculation Timer details.

NOTE: In order to set temperature for external recirculation mode, change from 7:RM to Etnl from installer mode and set one of three options LO (Low temp), HI-1 (Middle temp) and H1-2 (High temp) from 8:RT in installer mode.

! DANGER





Hotter water increases the risk of scald injury. Scalding may occur within 5 seconds at a setting of 140°F (60°C). Water temperature over 125°F can instantly cause severe burns, or death, from scalds. Children, disabled, and elderly are at the highest risk of being scalded. See instruction manual before setting temperature at appliance. Feel water before bathing or showering!

There are three Recirculation Timer settings: Act, SEt, and cLr. Act is used to set the Recirculation Timer type. SEt is used to manually set the day and times when the Recirculation Function will be active. cLr is used to clear and reset the Recirculation Timer setting.

The following section details the various Recirculation Timer Functions.

Step 1: Set the Recirculation Timer Type.		
Setting	Detail	Description
Act	Pro9	Allows the installer to customize the Recirculation Function. The recirculation day and time values must be set in Step 2, SET.
	Auto	When set in Smart Auto-Learn, the pump will run in Standard Mode for the first seven (7) days. During this period the water heater will monitor and record hot water usage patterns. After the initial seven (7) day learning period, the water heater will use the preceding week's usage pattern to cycle the pump and preheat the water.
Step 2: Set the Recirculation Run Time.		
Setting	Detail	Description
SET	Pro9	Pro9 is a factory set recirculation run time setting with day and time values. This setting can be customized for your installation. Day and Time can be programmed. Default: 6 - 7:30AM, 6 - 7:30 PM
Step 3: Reset the Recirculation Run Time setting.		
Setting	Setting	Setting
clr	Pro9	Resets the Pro9 or Auto Recirculation Run Time to the factory settings.
	Auto	

Table 28 – Recirculation Function Overview

- 1. Set the Recirculation Timer Type
 - a. Enter the Recirculation Timer by pressing  at Standby Mode while the water heater display is powered on.
 - b. Press the  button at the “Act” screen to select the Recirculation Timer type. See Figure 41. Turn the dial  to choose between “Auto” or “Pro9”.
 - c. Press the  button to select the Recirculation Timer Type.
 - d. The Recirculation Timer is now set.
- NOTE: If “Auto” is selected, the water heater will monitor and record hot water usage patterns over a period of seven (7) days. After this learning period, the water heater will use the usage pattern to automatically cycle the pump and preheat the water.
- NOTE: If “Pro9” is selected, continue to step 2 below to set the recirculation run time setting.

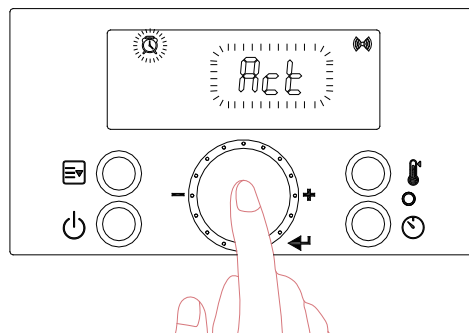





Figure 41 – Setting the Recirculation Timer Type

• 2. Setting the Recirculation Run Time (Pro9 Recirculation Timer)

NOTE: This step is only necessary if “Pro9” was selected as the Recirculation Timer Type. If “Auto” was selected the water heater will automatically program its recirculation operating patterns.

- Enter the Recirculation Timer by pressing  at Standby Mode while the water heater display is powered on.
- Turn the dial  until “SET” flashes on the screen. Press the  button at the “SET” screen to set the Recirculation Run Time. See Figure 42.

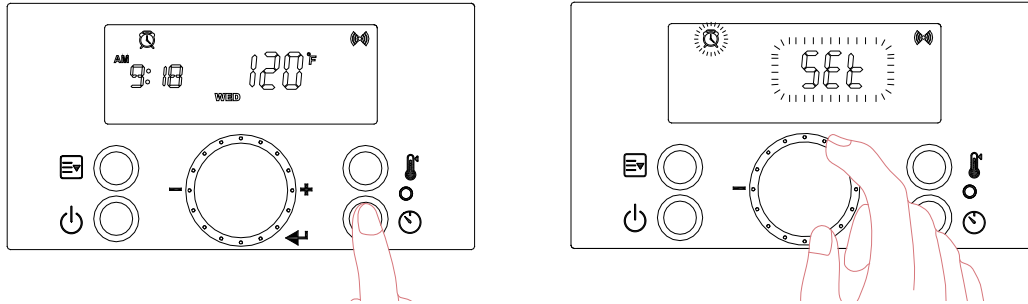







Figure 42 – Setting the Recirculation Run Time

- To set the day, ensure “Pro9” is on the display. Turn the dial . When the desired day appears on the screen, press the  button to select and store the day. Turn the dial  until the next desired day appears on the display. Press the  button to select and store the day. Repeat this step to include more days.
- Press and hold the  button for two (2) seconds to set the time.

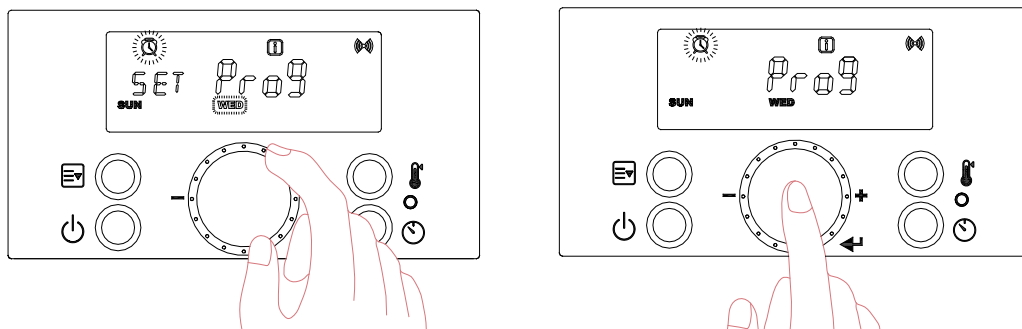

Figure 43 – Setting the Recirculation Day – In this Example, Sunday and Wednesday Are Chosen

- To set the time, ensure “Pro9” and “12:00” are on the display.

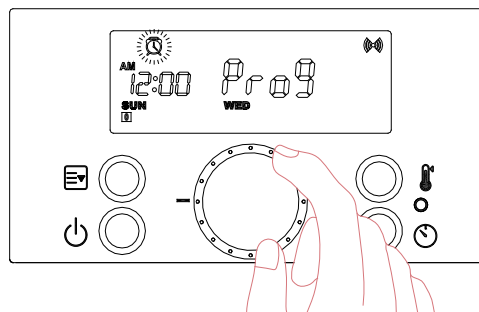





Figure 44 – Setting the Recirculation Time

f. Turn the dial . The start time on the screen will change in increments of thirty (30) minutes. When the desired start time appears on the screen, press the  button to select and store it. Next, turn the dial  until the desired end time appears on the display. Press the  button to select and store the end time. Repeat this step to set the start and end times for more days.

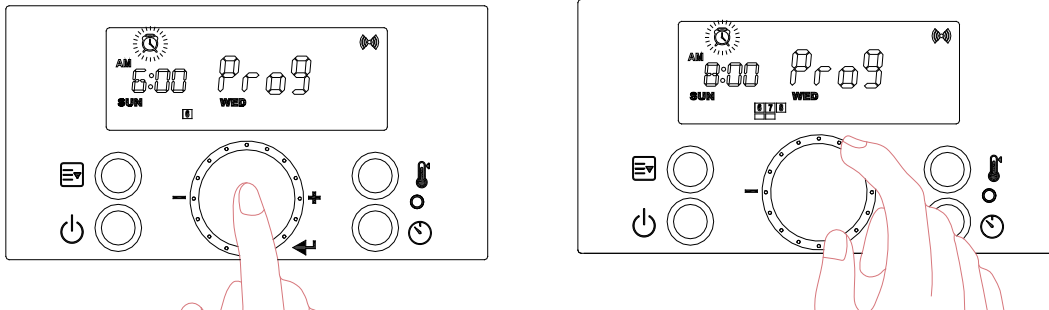



Figure 45 – Setting Start and End Recirculation Times

g. Press and hold the  button for two (2) seconds to store the time.
 h. If all settings are stored, press  to return to Standby Mode.

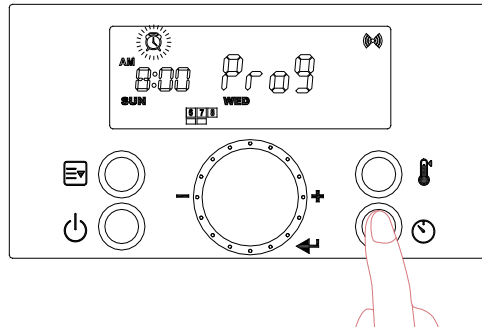





Figure 46– Storing Recirculation Run Time

•3. Resetting the Recirculation Run Time

NOTE: This step is only necessary if the “Pro9” or “Auto” Recirculation Run Times need to be reset. If “Auto” was selected the water heater will automatically program its recirculation operating patterns.

- Enter the Recirculation Timer by pressing  at Standby Mode while the water heater display is powered on.
- Turn the dial  until “cLr” flashes on the screen. Press the  button at the “cLr” screen to reset the Recirculation Run Time. See Figure 47.

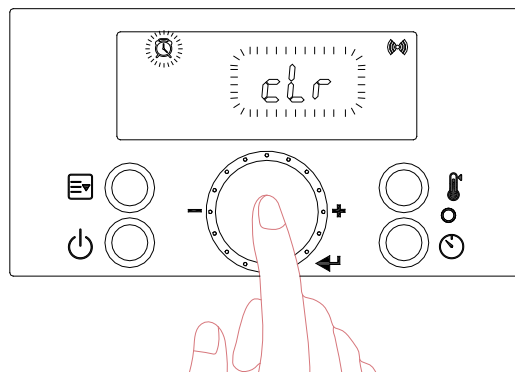



Figure 47 – Resetting the Recirculation Run Time

c. Turn the dial  to “Pro9” or “Auto”. Press  at the Recirculation Timer Type you wish to reset. See Figure 48.

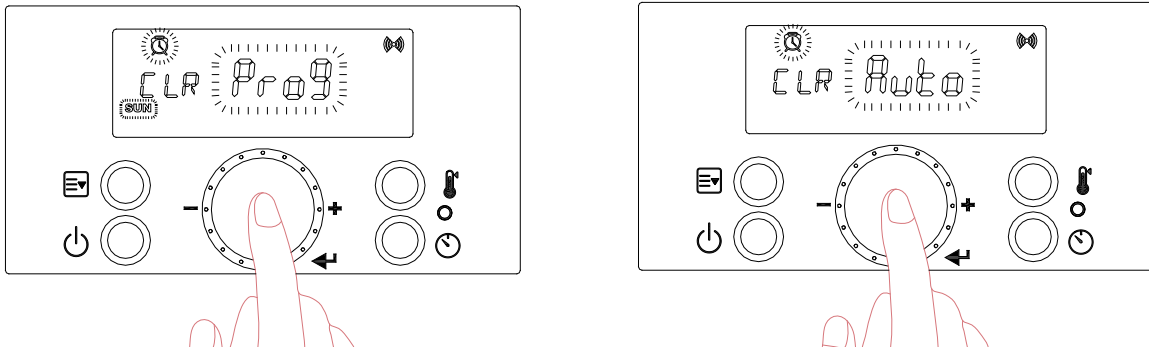



Figure 48 – Resetting the Recirculation Run Time

d. The Recirculation Run Time has now been reset to the factory default settings. Press  to return to Standby Mode.

NOTICE

If hot water is not used for more than thirty (30) hours, the recirculation program will be stopped and the water heater will automatically go into Vacation Mode and display the vacation icon .

▪ **J. ERROR MODE**

When the water heater encounters an error, the display will flash “Er” followed by a numerical code. The water heater shall enter a soft lockout condition if the error is such that it can return to normal operation once the condition relieves itself (overheat conditions, NTC open or shorts, etc.).

The water heater shall enter a hard lockout if the condition indicates something more serious (flame, ignition, condensate line, etc.) To clear a hard lockout Error Code, press the Power button. The following screen will display when the water heater encounters an error.

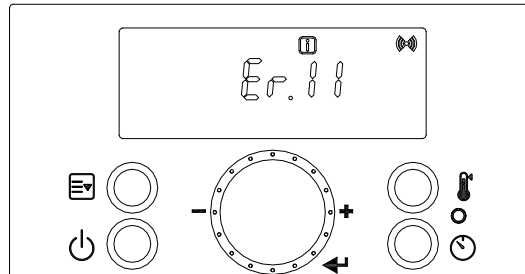

Figure 49 – Error Mode Screen

Error Code	Error Code Description	Possible Remedies
Er:10	Flame has been lost Eight (8) Times	<p>Press the Power button to clear the Error Code.</p> <p>If Error happens again:</p> <ol style="list-style-type: none"> 1. Monitor the gas pressure to the water heater while in operation. Ensure pressure is between 5.0" W.C and 13.0" W.C (1.25 to 3.24 kPa). 2. Check gas valve wire. Ensure connection is secure. 3. Check flame detection sensor. Ensure connections are secure. Normal operating settings are more than 2.5DC before ignition, less than 2.5DC after ignition. 4. Check igniter transformer for proper connection. 5. Clean the spark igniter with steel wool to remove oxides. Ensure proper separation (3-4 mm). 6. Replace the spark igniter if damaged. 7. Assure that the flame is stable when lit. 8. If the problem persists, replace the main control.
Er:11	Ignition has Failed 10 (Ten) Times	<p>Press the Power button to clear the Error Code.</p> <p>If Error happens again:</p> <ol style="list-style-type: none"> 1. Monitor the gas pressure to the water heater while in operation. Ensure pressure is between 5.0" W.C and 13.0" W.C (1.25 to 3.24 kPa). 2. Check gas valve wire. Ensure connection is secure. 3. Check flame detection sensor. Ensure connections are secure. Normal operating settings are more than 2.5DC before ignition, less than 2.5DC after ignition. 4. Check igniter transformer for proper connection. 5. Clean the spark igniter with steel wool to remove oxides. Ensure proper separation (3-4 mm). 6. Replace the spark igniter if damaged. 7. Assure that the flame is stable when lit. 8. If the problem persists, replace the main control.
Er:16	Operating Temperature Sensor or DHW Sensor detects Water Temperature Greater than 199°F (93°C)	<p>This Error Code will go away when the DHW temperature decreases.</p> <p>If Error happens again:</p> <ol style="list-style-type: none"> 1. Check if dip switch High Fire setting is ON. Switches 6 and 7 should be OFF for normal operation. 2. Check if DHW pipe is blocked. Ensure there is enough water flowing to the water heater. 3. Check DHW sensor at DHW outlet. If resistance is zero, replace the sensor. 4. Check Operating Temperature sensor at the heat exchanger. If resistance is zero, replace the sensor. 5. If the problem persists, replace the main control.

Error Code	Error Code Description	Possible Remedies
Er:20	High Limit Overheat Switch – Closed is Normal, Open is Fault	Press the Power button to clear the Error Code. 1. Inspect the High Limit Overheat switch. Ensure proper connections. 2. Check High Limit Overheat switch resistance. If resistance is zero, replace the switch. 3. If the problem persists, replace the main control.
Er:29	APS/Condensate – Closed is Normal, Open is Fault (Condensate Drain Trap)	Press the Power button to clear the Error Code. 1. Check APS/Condensate and main controller connections. Ensure all are secure. 2. Check APS/Condensate resistance. If resistance is zero, replace the switch. 3. Check APS/Condensate hose. Ensure it is connected and in good condition. 4. Check condensate line and termination for blockages. 5. Check exhaust vent for blockages. 6. If the problem persists, replace the main control.
Er:31	Water Inlet Sensor Open or Short	This Error Code will go away when inlet water temperature decreases. If Error happens again: 1. Check inlet water temperature sensor. Ensure connections are secure. 2. Check sensor resistance. If resistance is zero, replace the sensor. 3. If the problem persists, replace the main control.
Er:32	Water Outlet Sensor Open or Short	This Error Code will go away when outlet water temperature decreases. If Error happens again: 1. Check DHW outlet temperature sensor. Ensure connections are secure. 2. Check sensor resistance. If resistance is zero, replace the sensor. 3. If the problem persists, replace the main control.
Er:33	H/X Temperature Sensor Open or Short	This Error Code will go away when outlet water temperature decreases. If Error happens again: 1. Check operating temperature sensor. Ensure connections are secure. 2. Check sensor resistance. If resistance is zero, replace the sensor. 3. If the problem persists, replace the main control.
Er:35	Exhaust Sensor Open or Short	This Error Code will go away when exhaust temperature decreases. If Error happens again: 1. Check exhaust temperature sensor. Ensure connections are secure. 2. Check sensor resistance. If resistance is zero, replace the sensor. 3. Check exhaust vent for blockage. 4. If the problem persists, replace the main control.
Er:39	Flame Detected after Exiting a Flame On Condition	This Error Code will go away when the false flame condition is remedied. If Error happens again: 1. Check the water heater cover. Ensure it is secure. Flame detection sensor can detect an external light source. 2. Check flame detection sensor. Ensure connections are secure. Normal operating settings are more than 2.5DC before ignition, less than 2.5DC after ignition. 3. If the problem persists, replace the main control.
Er:40	Gas Leakage continuously detected for 10 Minutes, or three times within One Hour (Greater than 5 Seconds Each Time)	IMPORTANT: If you smell gas, STOP! Follow the instructions on page 2, this manual, and call a qualified service technician or the fuel gas utility. Press the Power button to clear the Error Code. If Error happens again: 1. Check the water heater cover. Ensure it is secure. 2. Check gas connections for leakage with a soapy solution. Fix any leaks. 3. Check condition of the burner assembly. 4. If the problem persists, replace the main control.

Error Code	Error Code Description	Possible Remedies
Er:41	Fan Speed too High with Flame On	<p>Press the Power button to clear the Error Code.</p> <p>If Error happens again:</p> <ol style="list-style-type: none"> 1. Check the vent connections for blockages. 2. Check the burner assembly. 3. Check fan operation. If fan appears to be operating normally but RPMs are too low or too high, replace the fan. 4. If the problem persists, replace the main control.
Er:43	Burner Overheat Switch Open	<p>Press the Power button to clear the Error Code.</p> <p>If Error happens again:</p> <ol style="list-style-type: none"> 1. Check burner overheat switch connections. Ensure connections are secure. 2. Check switch resistance. If resistance is zero, replace the switch. 3. If the problem persists, replace the main control.
Er:44	Recirculation Abnormality	<p>Press the Power button to clear the Error Code.</p> <p>If Error happens again:</p> <ol style="list-style-type: none"> 1. Ensure water heater inlet and outlets are open and water is supplied to the water heater. 2. Check the pump operation. 3. If it doesn't work, ensure wiring connections to pump. 4. If even supply power to pump and doesn't run it replace the pump. <p>If Error happens again:</p> <ol style="list-style-type: none"> 1. Verify recirculation loop length is within specification. Air purge is not enough. 2. Too much restriction on recirculation loop. 3. Return loops are clogged. 4. Check the recirculation loop condition
Er:45	Water Leak	<ol style="list-style-type: none"> 1. Turn power off to the water heater. 2. Valve off the water heater to isolate it from the system. 3. Call a qualified service technician to diagnose and repair the source of the leak.
Er:60	Hot Water Temperature Abnormality	<p>Press the Power button to clear the Error Code.</p> <p>If Error happens again:</p> <ol style="list-style-type: none"> 1. Ensure water heater inlet and outlets are open and water is supplied to the water heater. <p>If Error happens again:</p> <ol style="list-style-type: none"> 1. Ensure water heater inlet and outlets are open and water is supplied to the water heater. 2. Check the pump operation. 3. If it doesn't work, ensure wiring connections to pump. 4. If even supply power to pump and doesn't run it, replace the pump. <p>If Error happens again:</p> <ol style="list-style-type: none"> 1. Verify recirculation loop length is within specification. Air purge is not enough. 2. Too much restriction on recirculation loop. 3. Return loops are clogged. 4. Check the recirculation loop condition.
Er:61	Fan Speed Feedback Signal Abnormal	<p>This Error Code will go away when the condition is remedied.</p> <p>If Error happens again:</p> <ol style="list-style-type: none"> 1. Check the connections to the fan. Ensure all are secure. 2. If the fan does not rotate during the ignition sequence, check for DC15~30V power at the fan connection. If DC15~30V power is present at the control, replace the fan. If the blower does not have DC15~30V power, check power at the control. If DC15~30V power is not present at the control, replace the control. 3. If the problem persists, replace the main control.
Er:65	Supply Water Valve Error	<p>Press the Power button to clear the Error Code.</p> <p>If Error happens again:</p> <ol style="list-style-type: none"> 1. Turn power OFF and ON at the main power switch internal to the water heater. 2. Check wiring connections to supply water valve. Ensure all are secure. 3. Replace supply water valve. 4. If the problem persists, replace the main control.

Error Code	Error Code Description	Possible Remedies
Er:66	Mixing Valve Error	<p>Press the Power button to clear the Error Code.</p> <p>If Error happens again:</p> <ol style="list-style-type: none"> 1. Turn power OFF and ON at the main power switch internal to the water heater. 2. Check wiring connections to mixing valve. Ensure all are secure. 3. Replace mixing valve. 4. If the problem persists, replace the main control.
Er:67	AGM Error	<p>Press the Power button to clear the Error Code.</p> <p>If Error happens again:</p> <ol style="list-style-type: none"> 1. Turn power OFF and ON at the main power switch internal to the water heater. 2. Ensure fan inlet hole is completely open after turning the power OFF and ON. 3. Check wiring connections to the AGM. Ensure all are secure. 4. Check AGM operation. 5. Replace AGM components. 6. If the problem persists, replace the main control.
Er:72	Flame Signal Detected before Ignition	<p>This Error Code will go away when the condition is remedied.</p> <p>If Error happens again:</p> <ol style="list-style-type: none"> 1. Check the water heater cover. Ensure it is secure. Flame detection sensor can detect an external light source. 2. Check flame detection sensor. Ensure connections are secure. Normal operating settings are more than 2.5DC before ignition, less than 2.5DC after ignition. 3. If the problem persists, replace the main control.
Er:73	DIP Switch is abnormal	<p>This Error Code will go away when the condition is remedied.</p> <p>If Error happens again:</p> <ol style="list-style-type: none"> 1. Check dip switches. Ensure switches match the ratings plate requirements of the water heater. See dip switch details, this manual, for default settings. 2. If the problem persists, replace the main control.
Er:76	Poor Communication	<p>This Error Code will go away when the condition is remedied.</p> <p>If Error happens again:</p> <ol style="list-style-type: none"> 1. Check connections from main control to display panel. 2. If the problem persists, replace the display and/or the main control.
Er:78	Cascade Communication Error	<p>NOTE: This error will only appear in a cascaded system.</p> <ol style="list-style-type: none"> 1. Turn power OFF and ON at the appliance display panel. 2. If error reappears, ensure all cascaded appliances are powered ON. 3. If error reappears, check Installer Mode parameter 10:Cn at among the both units. Ensure the setting as "on" in 10:Cn of Installer Mode. 4. If error reappears, check the wire cables into the 'Main PCB' connector inside both units. Ensure the connection of cascade cable between both appliances. 5. If there was no problem wiring connection, replace damaged cables. 6. If the problem persists, replace the main control.
Er:94	Exhaust NTC detects Vent Temperature is Greater than 149°F / 65°C (185°F / 85°C when High Temp set point is Selected)	<p>This Error Code will go away when the condition is remedied.</p> <p>If Error happens again:</p> <ol style="list-style-type: none"> 1. Check if dip switch High Fire setting is ON. Switches 6 and 7 should be OFF for normal operation. 2. Check exhaust temperature sensor. Ensure connections are secure. 3. Check sensor resistance. If resistance is zero, replace the sensor. 4. Check exhaust vent for blockage. 5. If the problem persists, replace the control. 6. If the problem persists, replace the heat exchanger.

Table 29 –Diagnostics and Suggested Corrective Actions

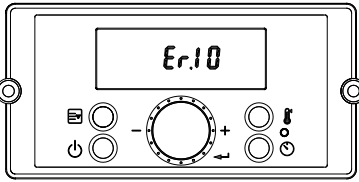
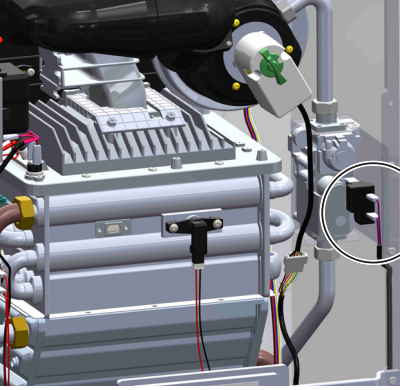
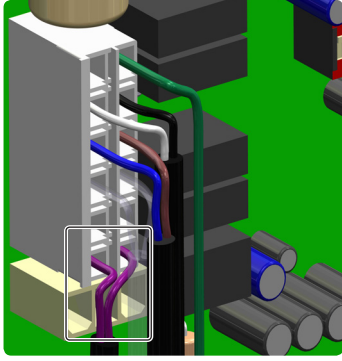
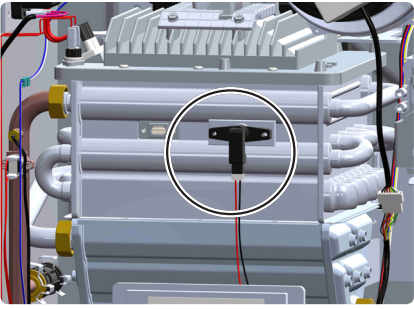
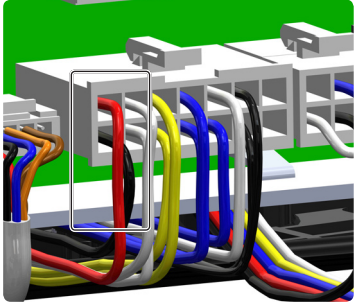
Error code	Meaning	Condition
	<p>Flame Loss (Manual restore)</p>	<p>If flame extinction issue repeats 8 times while combusting error code 10 will appear.</p>
<p>Failure event</p>		
<p>If flame loss occurs 8 consecutive times during combustion, the Er.10 will be displayed, the burner will turn off the flame, and the fan will post-purge.</p>		
<p>Check point</p>		
	<p>① Check gas valve connecting line.</p>	 <p>② Check wire color of connector. (CN 9 : Purple/ Purple ⑥, ⑫)</p>
	<p>③ Check flame detector sensor's connecting line and fixed spot.</p>	 <p>④ Check wire color of connector. (CN 7 : red ① , black ⑧)</p>
<p>⑤ Check the flue. (Air intake& exhaust pipe) ⑥ If the above issues are operating normally, replace circuit board.</p>		

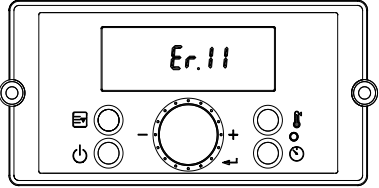
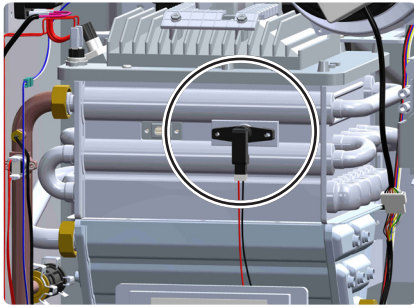
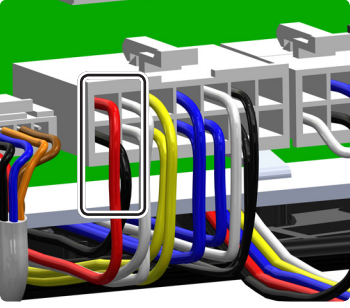
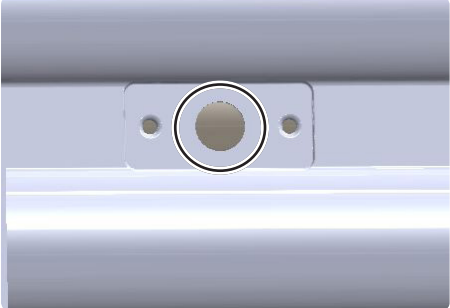
Error code	Meaning	Condition
	Ignition failure (Manual restore)	During burning operation, if it failed to ignite 10 times continuously, error code 11 will appear.
Failure event		
If it failed to detect flame during ignition sequence pre-purge time will exceed 10 secs, and post-purge will be performed after the ignition causes manual restore error.		
Check point		
	① Check flame detector sensor's connecting line and fixed spot.	 ② Check wire color of connector. (CN 7 : red ① , black ②)
	③ Check color changes of flame observation port. After separating stop ring by seeing color changes, replace the flame observation port.	
<ul style="list-style-type: none"> ■ From more than DC 2.5V after ignition safety cut-off will appear <ul style="list-style-type: none"> ① When setting before ignition is less than DC 2.5V : Replace flame sensor. ② When setting before ignition is more than DC 2.5V : Replace the flame observation glass and gasket. 		

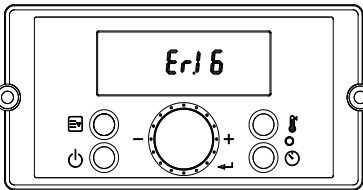
Error code	Meaning	Condition
	Operating Temperature and DHW Temperature Sensor (Automatic restore)	In the case of DHW mode, when the Operating Temperature and DHW temperature are detected higher than 199°F (93°C), error code 16 will appear.



Failure event

When Operating Temperature and DHW temperature are more than 199°F (93°C), DHW overheating error issue will appear and all the outputs except post-purge will stop. When lower than 176°F(80°C) it will restore automatically.

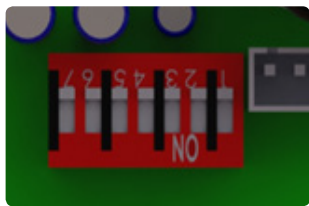
Check point

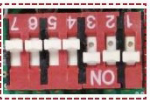
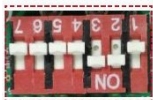

① Check the Circuit Board dip switch settings.

Fire	199,000Btu (LP)	180,000Btu (LP)	199,000Btu (NG)	180,000Btu (NG)
Normal Fire				

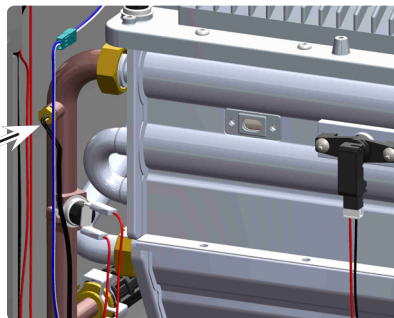
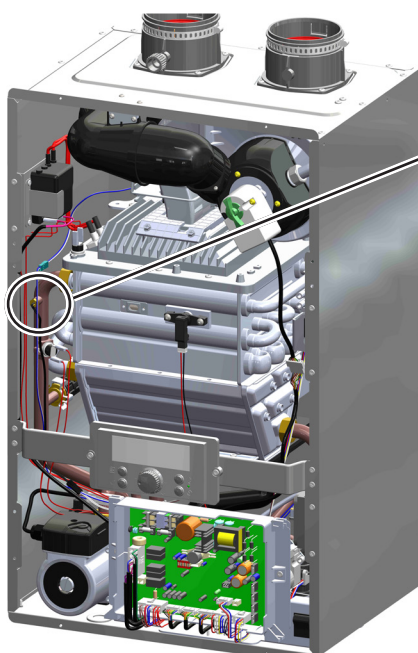

② If the value is 0Ω by measuring with a multi-meter machine, replace Overheating HEX Thermistor.

- The wires of CN 7 in circuit board : White/White (②,⑨)

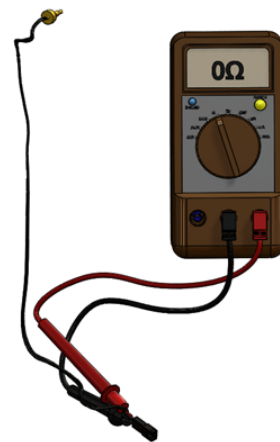
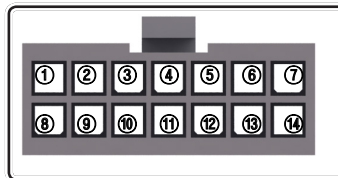

- HEX Outlet thermistor : Wire color (Black), Connector color (Black)

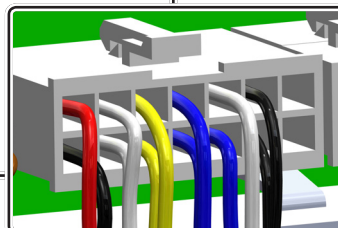
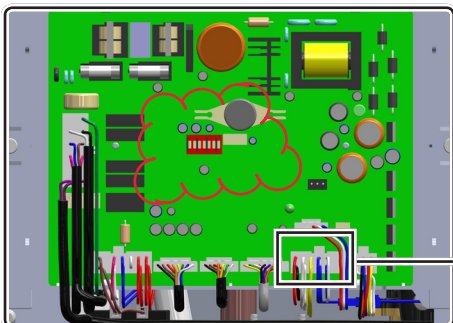

- Wire from PCB : Wire color (White), Connector color (Black)

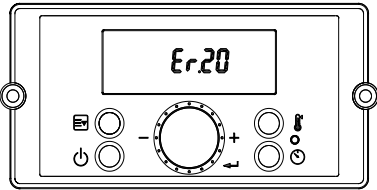
Error code	Meaning	Condition
	<p>High Limit Switch Abnormality (Manual restore)</p>	<p>When the High Limit Switch temperature is overheated, error code 20 will appear.</p>

Failure event

An Er. 20 will display if the temperature of the heating water exiting the primary heat exchanger exceeds the High Limit Switch's default settings. Combustion will stop and the fan will continue to run for post-purge.

Check point

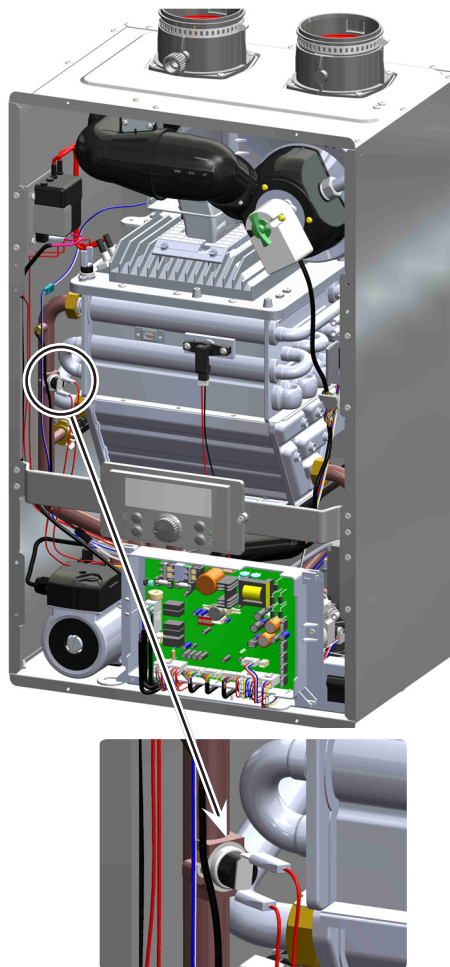

- ① Inspect the High Limit Switch when error code appears even if the heating supply temperature is not too high.
- ② Check connector and if no problem, measure High Limit Switch located at heat exchanger outlet and replace when the multi-meter value shows 'OL'. (Normal value is '0~0.5Ω') (CN 11 : red ⑬, ⑭)
- ③ Check the circulation pump speed setting as speed.

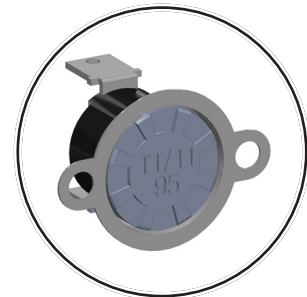
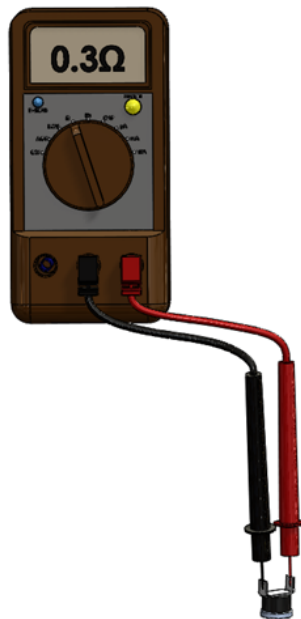

High Limit Switch
(203°F/95°C)

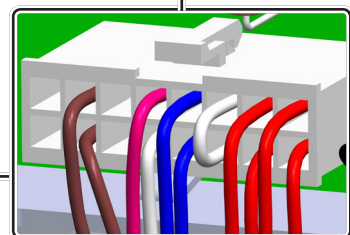
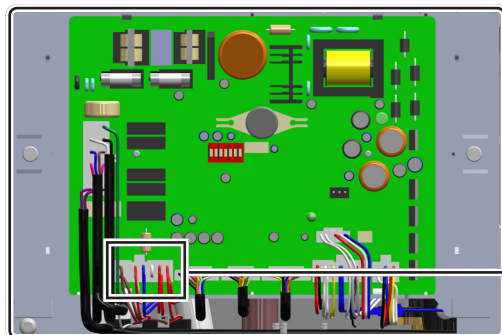
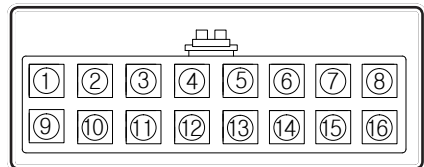

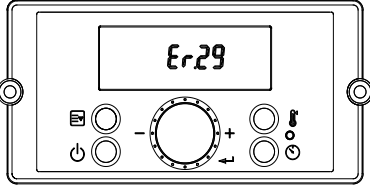
Error code	Meaning	Condition
	Air Pressure Switch (APS) Abnormality (Manual restore)	When APS at condensate discharging outlet is abnormal , error 29 will appear.

Failure event

Air pressure increase is most likely the result of an obstruction in the exhaust air flow line - for example, excessive condensate buildup or a blockage in the vent termination.

Check point

- ① Check APS and circuit board connection.
- ② Verify that the condensate trap and drain pipe are free of obstructions.
- ③ Check condensate discharging outlet is blocked by foreign substances.
- ④ Check the connecting hose between the condensate trap and APS.

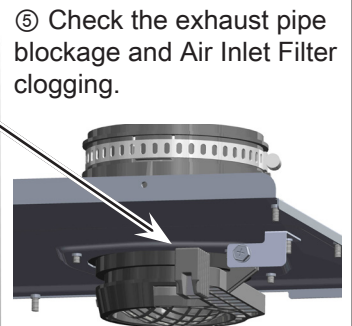
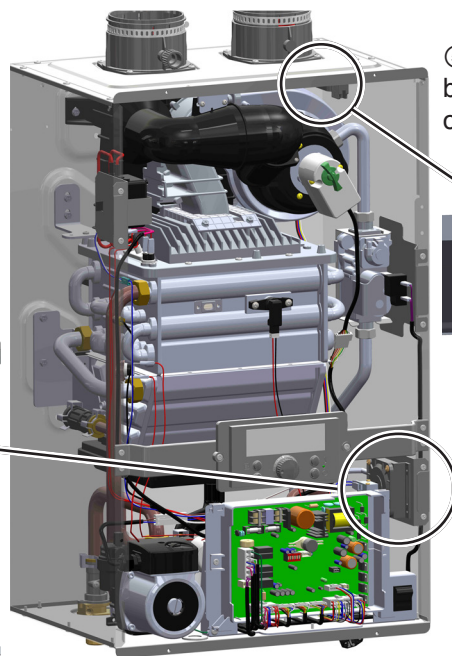
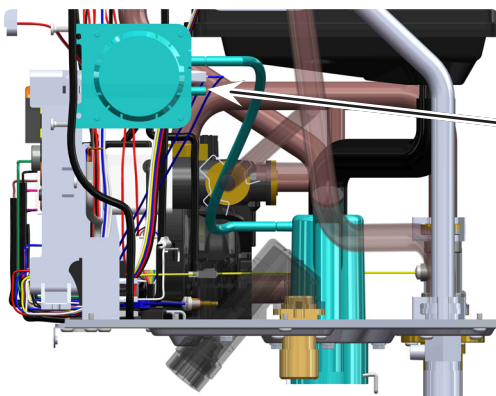

- ⑥ If above ①,②,③ check points are normal, check the APS connector to the multimeter. Replace APS when the multi-meter value shows 'OL'. (Normal value is '0~0.5Ω'.)

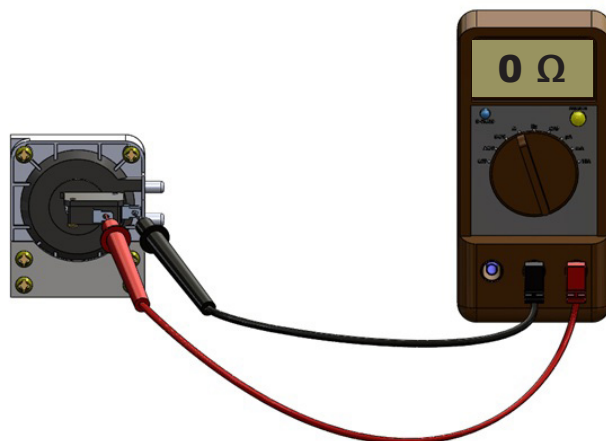

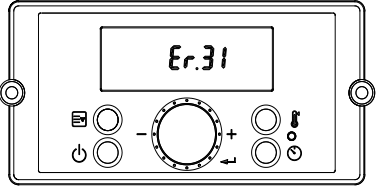
Error code	Meaning	Condition
	DHW Inlet Thermistor Open or Short Circuit (Automatic restore)	When no response at DHW Inlet Thermistor, error code 31 will appear.

Failure event

When DHW Inlet Thermistor's wiring line located at DHW Inlet connection is disconnected.

Check point

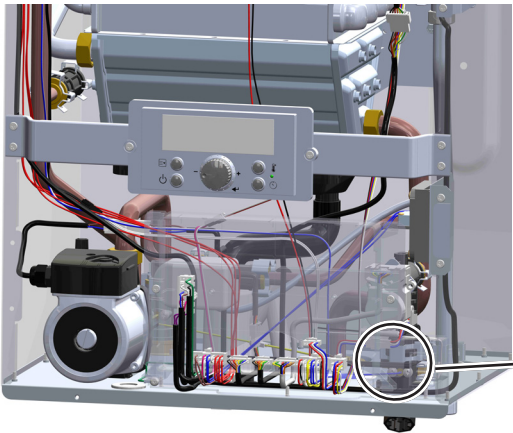

① Verify that the DHW Inlet Thermistor is properly secured in the cold water connection. Verify proper connection of the DHW Inlet Thermistor's wiring to the circuit board. (CN7 : blue ④, blue ⑩)

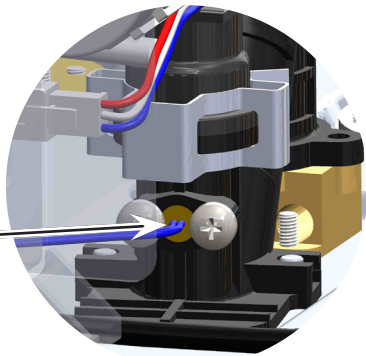

DHW Inlet (blue/blue)



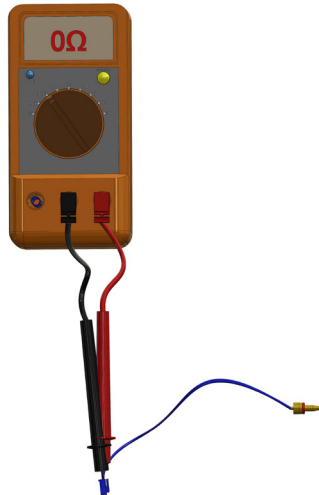

② Measure resistance across the DHW Inlet Thermistor with a multi-meter. If the multi-meter displays 0Ω (short circuit), replace the DHW Inlet Thermistor.

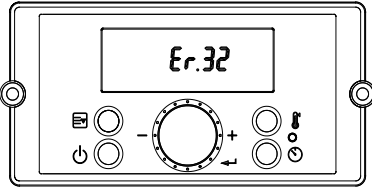
Error code	Meaning	Condition
	DHW Outlet Thermistor Open or Short (Automatic restore)	When no response at DHW Outlet Thermistor, error code 32 will appear.

Failure event

When DHW Outlet Thermistor's wiring line located at DHW connection is disconnected.

Check point

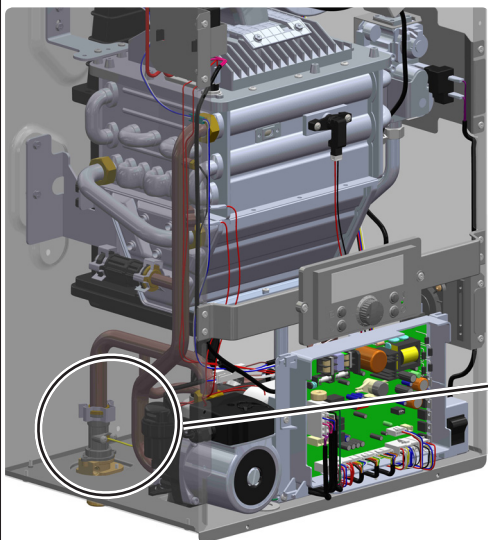

① Verify that the DHW Outlet Thermistor is properly secured in the DHW water connection. Verify proper connection of the DHW Outlet Thermistor's wiring to the circuit board.
(CN7 : Yellow ③, Yellow ⑩)

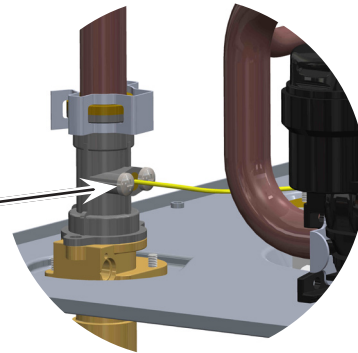

Hot Water Outlet (Yellow/Yellow)



② Measure resistance across the DHW Outlet Thermistor with a multi-meter. If the multi-meter displays 0Ω (short circuit), replace the DHW Thermistor.

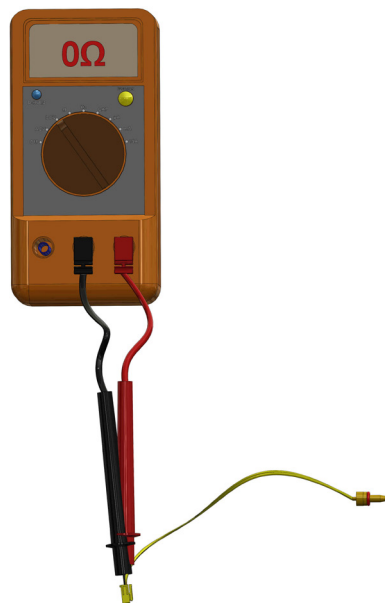

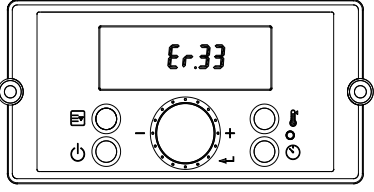
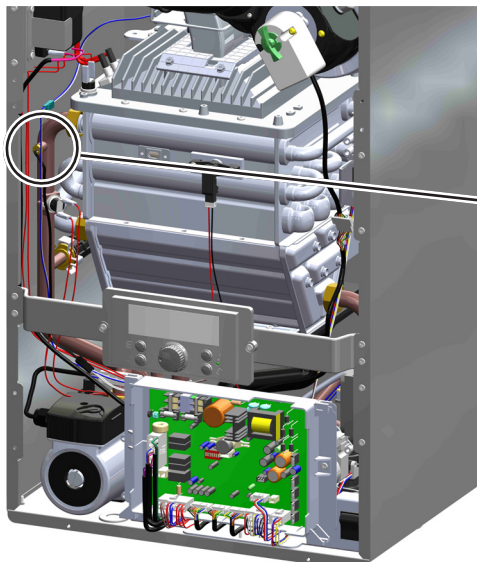
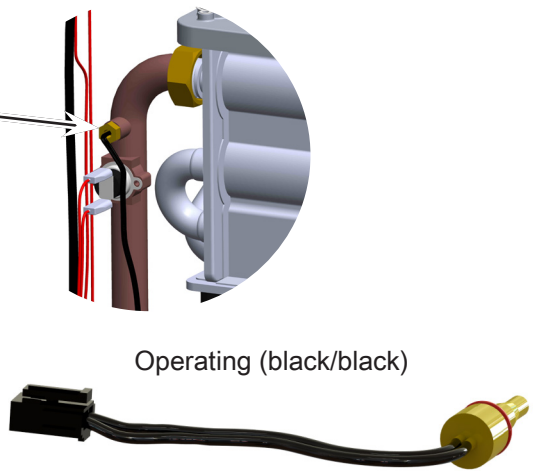
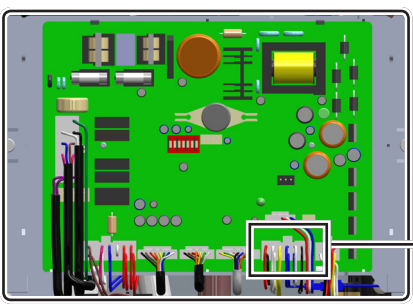
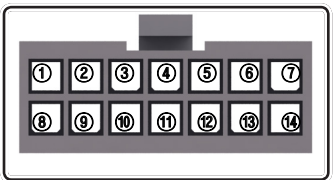
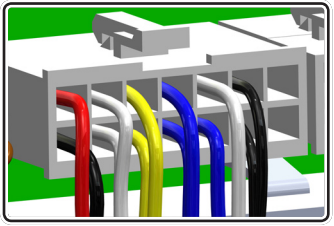
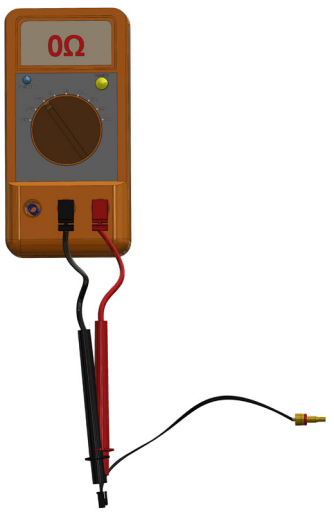
Error code	Meaning	Condition
	<p>Operating Thermistor Open or Short Circuit (Automatic restore)</p>	<p>When no response at operating Thermistor, error code 33 will appear.</p>
Failure event		
<p>When operating Thermistor's wiring line located at Hot Water Outlet Pipe is disconnected.</p>		
Check point		
	<p>① Verify that the Operating Thermistor is properly secured in the Hot water supply connection. Verify proper connection of the Operating Thermistor's wiring to the circuit board.</p>  <p>Operating (black/black)</p>	
<p>② Measure resistance across the Operating Thermistor with a multi-meter. If the multi-meter displays 0Ω (short circuit), replace the Operating Thermistor.</p> <ul style="list-style-type: none"> - The wires of CN 7 in circuit board : White/White (②,⑨) - Operating thermistor : Wire color (Black), Connector color (Black) 	  	

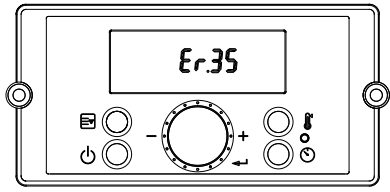
Error code	Meaning	Condition
	Exhaust Thermistor Open or Short Circuit (Automatic restore)	When no response at Exhaust Thermistor, error code 35 will appear.

Failure event

When Exhaust Thermistor's wiring line located at Exhaust is disconnected.

Check point

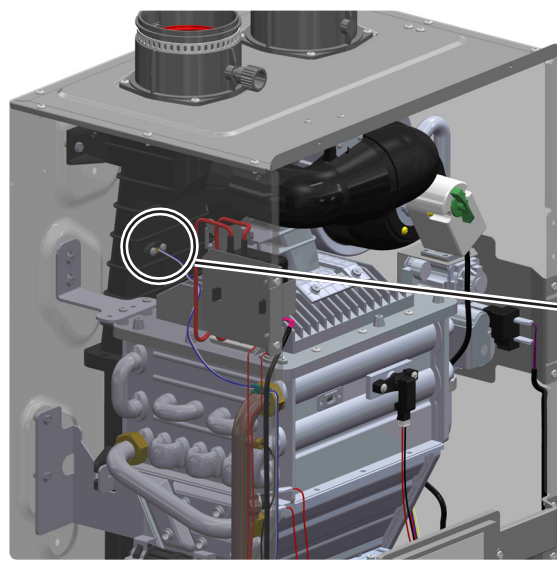

① Verify that the Exhaust Thermistor is properly secured in the exhaust connection. Verify proper connection of the Exhaust Thermistor's wiring to the circuit board. (CN7 : White ⑤, Blue ⑫)

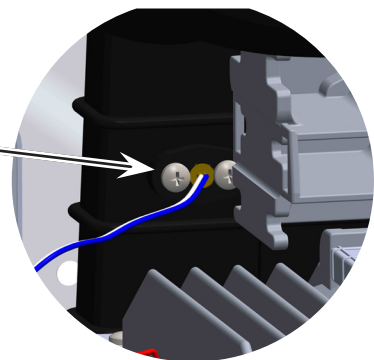

Exhaust (White / Blue)

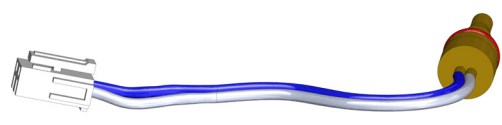

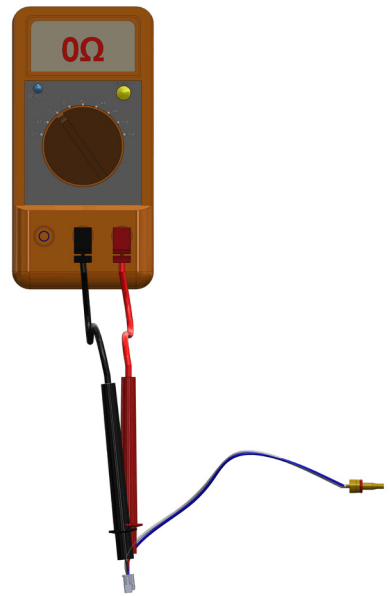

② Measure resistance across the Exhaust Thermistor with a multi-meter. If the multi-meter displays 0Ω (short circuit), replace the Exhaust Thermistor.

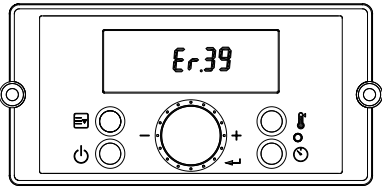
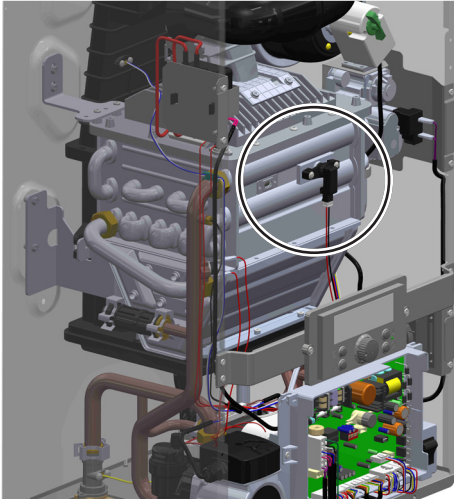

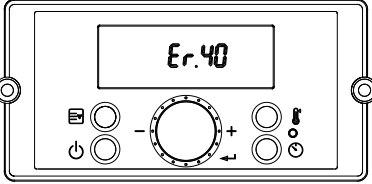
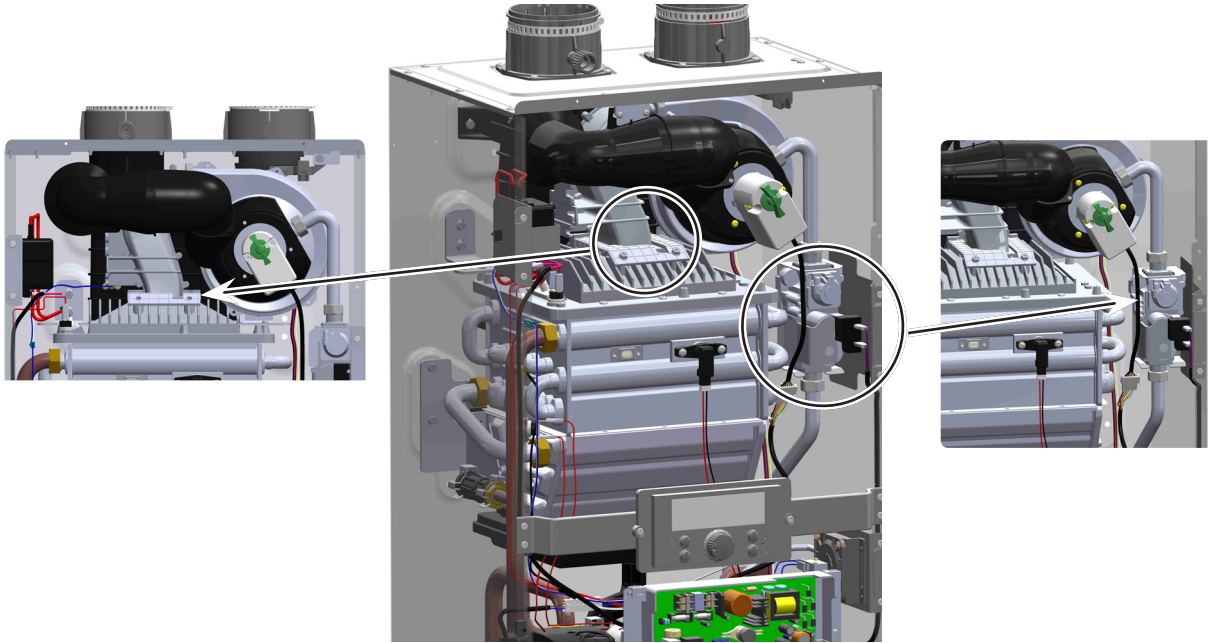
Error code	Meaning	Condition						
	<p>False flame sensing (Automatic restore)</p>	<p>If false flame is detected after combustion is ended error code 39 will appear.</p>						
Failure event								
<p>After completion of the water heater combustion flame detection sensor detects In case the flame generated.</p>								
Check point								
<p>① check the front cover will be closed.</p>								
<p>■ From more than DC 2.5V after ignition safety cut-off will appear</p> <ul style="list-style-type: none"> ① When setting before ignition is less than DC 2.5V : Replace flame sensor. ② When setting before ignition is more than DC 2.5V : Replace the flame observation glass and gasket. 								
	<table border="1" data-bbox="711 1028 1374 1160"> <thead> <tr> <th data-bbox="711 1028 954 1072">ITEM</th> <th data-bbox="954 1028 1374 1072">Normal Value</th> </tr> </thead> <tbody> <tr> <td data-bbox="711 1072 954 1117">Before ignition</td> <td data-bbox="954 1072 1374 1117">More than DC 2.5V</td> </tr> <tr> <td data-bbox="711 1117 954 1160">After ignition</td> <td data-bbox="954 1117 1374 1160">Less than DC 2.5V</td> </tr> </tbody> </table>		ITEM	Normal Value	Before ignition	More than DC 2.5V	After ignition	Less than DC 2.5V
ITEM	Normal Value							
Before ignition	More than DC 2.5V							
After ignition	Less than DC 2.5V							

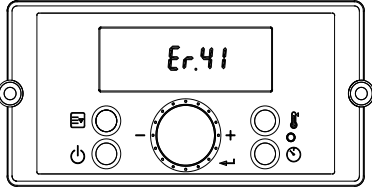
Error code	Meaning	Condition
	Gas leakage (Manual restore)	When gas leakage is detected during operation error code 40 will appear.
Failure event		
<p>Stop all of the outputs except fan when detecting gas leakage signal for over 1 sec, it restores automatically after 5 min. When detecting more than 10 min continuously or 3 times in a hour, restore error manually. When leakage doesn't occur for one hour, past leakage history will be deleted.</p>		
Check point		
<ol style="list-style-type: none"> ① Turn off the gas. ② Check leakage part with using soapy water at the gas valve and flue joint, and re-assemble when leakage is found. Check condition of o-ring and packing and replace it. ③ Check joint condition of burner parts. ④ Verify the venting so it is installed correctly. <div style="text-align: center; margin-top: 20px;">  </div>		

Error code	Meaning	Condition
	Excess Fan Speed detected (Manual restore)	When fan speed exceeds normal values during combustion, error code 41 will appear.
Failure event		
<p>The circuit board has Fan Speed data. Before ignition, compare with standard Fan Speed before ignition and error appears when exceeding standard range, stop all of the outputs except post-purge.</p>		
Check point		
	<ol style="list-style-type: none"> ① Check APS and circuit board connection. ② Verify that the condensate trap and drain pipe are free of obstructions. ③ Check the exhaust and intake pipes for blockage. ④ To reset this error code, the power needs to be disconnected and then reconnected. 	

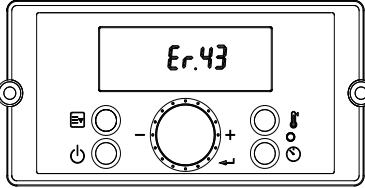
Error code	Meaning	Condition
	Burner Limit Switch abnormality (Manual restore)	Burner Limit Switch's temperature is above the acceptable range, error code 43 will appear.

Failure event

Stop all of the outputs except fan when Burner Limit Switch attached on burner upper plate shows temperature above 302°F(150°C).

Check point

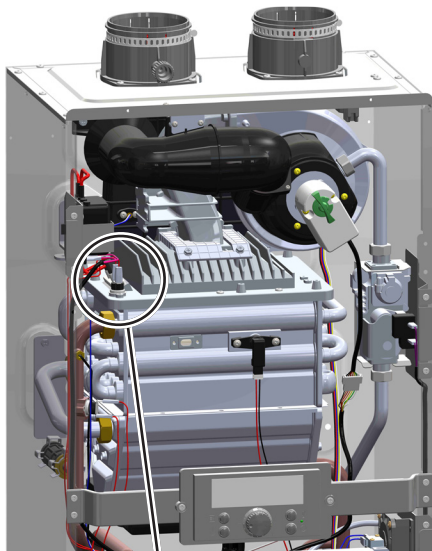

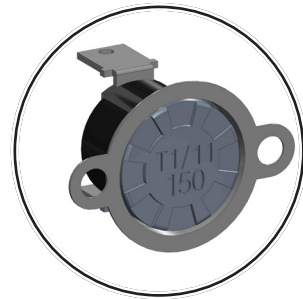
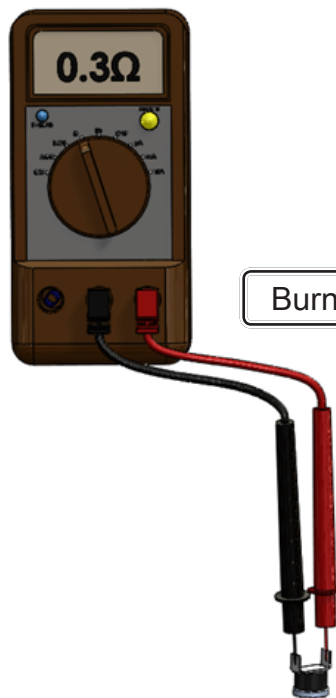
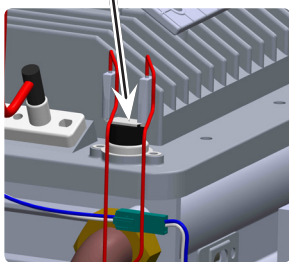

- ① Check conditions of burner limit switch connected with burner and circuit board, and disconnection.
- ② Check connector and if no problem, measure burner limit switch located at burner head and replace overheating switch when the multi-meter value shows 'OL'. (Normal value is '0~0.5Ω'.) (CN 11 : Red ⑦, ⑯)

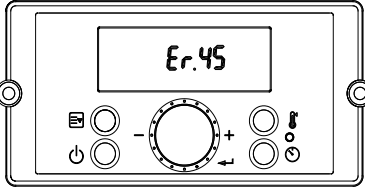
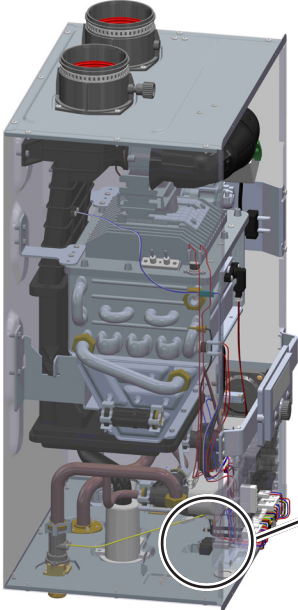
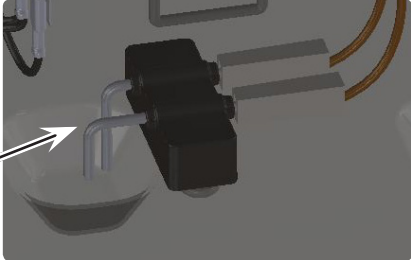

Burner Limit Switch (302°F/150°C)

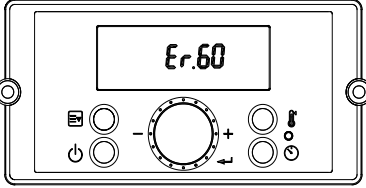
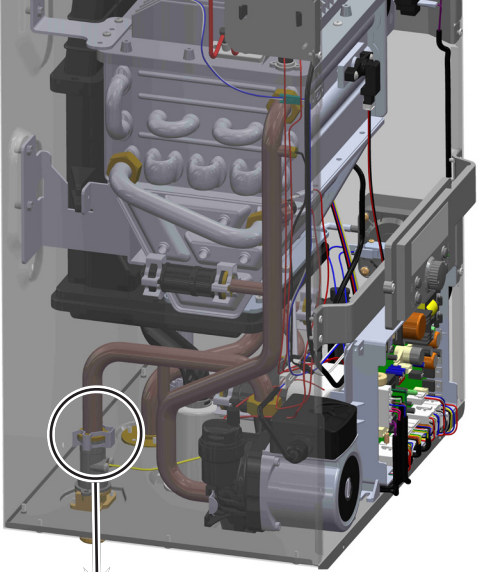
Error code	Meaning	Condition
	Water Leakage (Manual restore)	When the Water Leakage Detector detects water, error code 45 will appear.
Failure event		
Stop all of the outputs except fan when the Water Leakage Detector attached on base under plate detected the water, it restores manually.		
Check point		
<div style="display: flex; align-items: flex-start;"> <div style="flex: 1;">  </div> <div style="flex: 2;"> <ol style="list-style-type: none"> ① Close the water inlet valve. ② Check the Water Leakage Detector's wire. (CN11 : brown ②, ⑩) ③ If there is standing water, find the leakage area, replace the part. </div> <div style="flex: 1; text-align: center;">  </div> </div>		

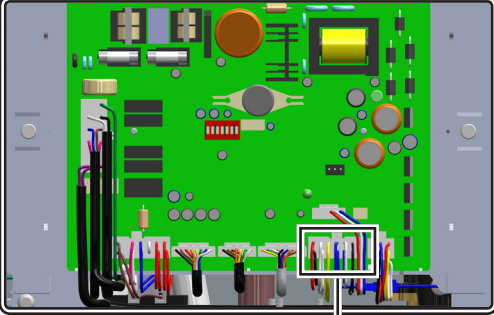
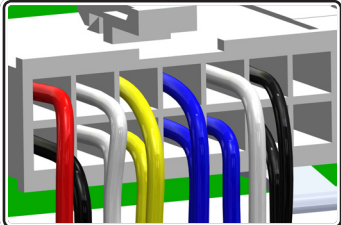
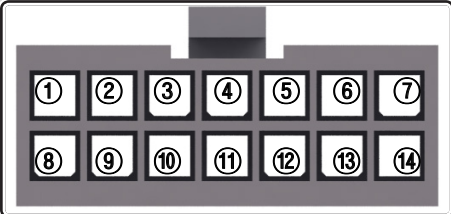
Error code	Meaning	Condition
	<p>Hot Water Temperature Abnormality. (Manual restore)</p>	<p>When DHW is overheated than default temperature, the error code 60 is occurred.</p>
Failure event		
<p>DHW temperature is over 167°F(75°C) and when the error occurred, close Cold water inlet valve and operate the pump.</p>		
Check point		
 <p>Hot Water Outlet (CN7:③ yellow/ ⑩ yellow)</p> 	  	
<ol style="list-style-type: none"> ① When DHW temperature is overheated, the error is occurred to minimize the damage by the overheated DHW. ② If the error is occurred when DHW temperature is not reached to set temperature, check DHW temperature sensor. ③ If there is standing water, find the leakage area, replace the part. ④ If the error is occurred when DHW temperature is overheated(over 167°F(75°C)), inspect DIP switch setting. (Default : No.6&7 OFF) ⑤ If circulation pipe has error, after recirculation operating the error is occurred when DHW on demand. ⑥ Check that the recirculation operating is normal. ⑦ Check the internal or external recirculation setting. ⑧ When water temperature of Heat Exchanger and DHW temperature are lower than set temperature, it will be automatically restored. 		

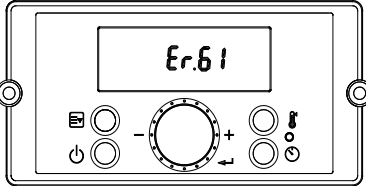
Error code	Meaning	Condition
	Fan RPM Sensor Abnormality (Automatic restore)	When the Fan RPM Sensor is abnormal state, error code 61 will appear.

Failure event

Stop all of the outputs when Fan RPM Sensor is connected to an abnormal state.
(Refer to installation manual)

Check point

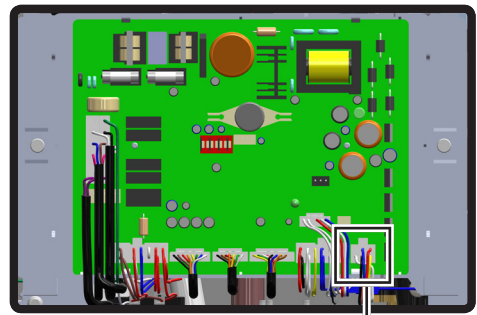
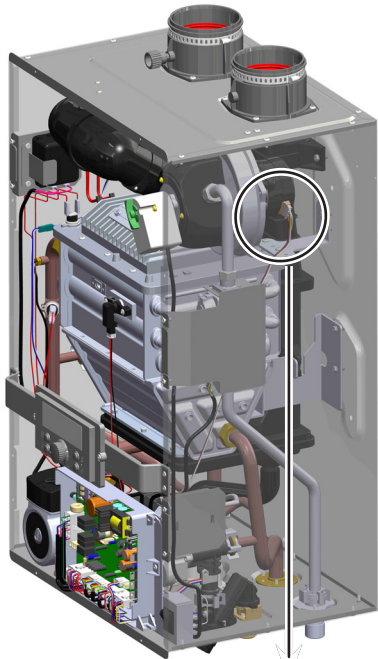

① Check wiring line connection carefully.

- Fan Start Coil (white) ④ : connector ④
- RPM Sensor (yellow) ③ : connector ⑥
- GND (blue) ② : connector ②
- VDD (red) ① : connector ③
- Fan End Coil (black) ⑤ : connector ⑤

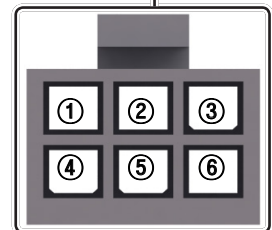
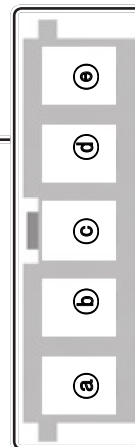
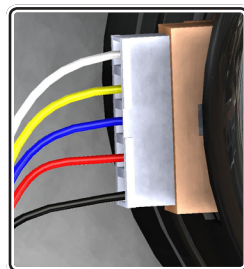
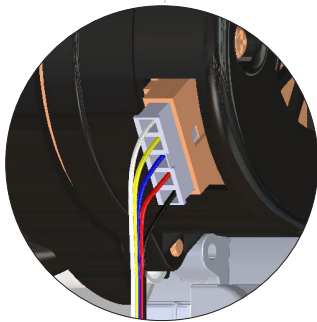
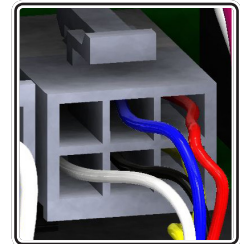

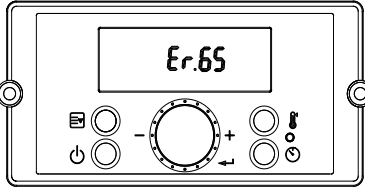
Error code	Meaning	Condition
	<p>Flow Control Valve error (Manual restore)</p>	<p>① Occurs manual restore error. ② Not able to supply hot water to the set temperature when flow rate exceeds hot water heater's capacity. ③ Flow rate doesn't increase during malfunction when valve is locked.</p>

Failure event

Not able to sense reference point or motor doesn't rotate due to malfunction.

Check point

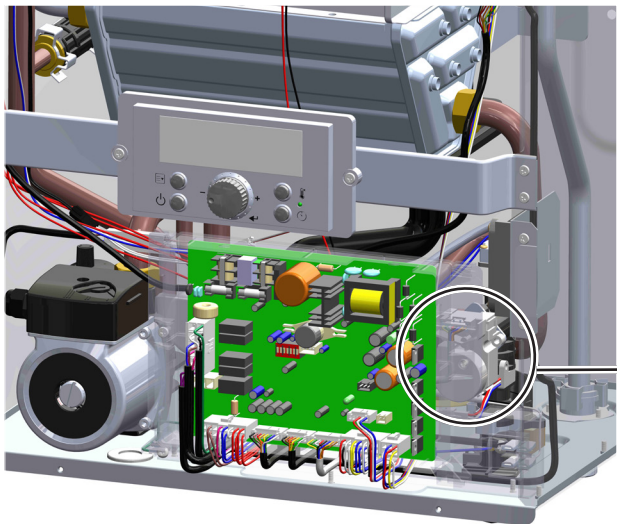

① Check error code sign after turning off and on the power.

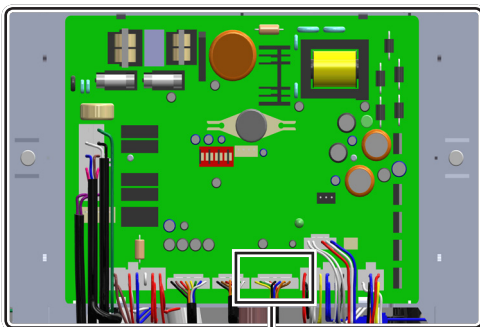
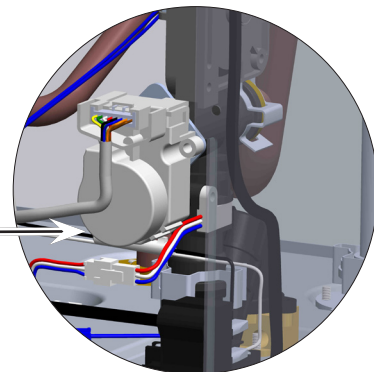

② Check wiring line connection carefully.
③ Verify proper connection of the Flow Control Valve Thermistor's wiring to the circuit board.
(CN14 : ①Yellow,②Green,③White,④Red,⑤Black,⑥Blue,⑦Orange,⑧Brown)

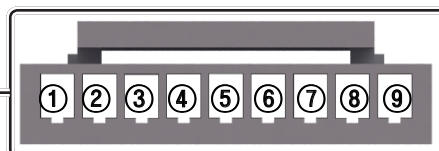
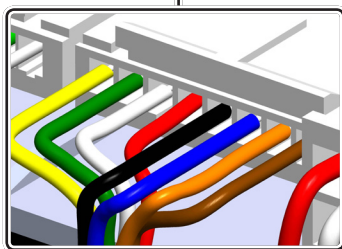

③ If above ①, ② operates abnormally replace Flow Control Valve.

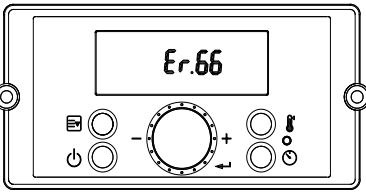
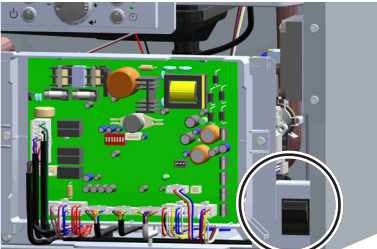
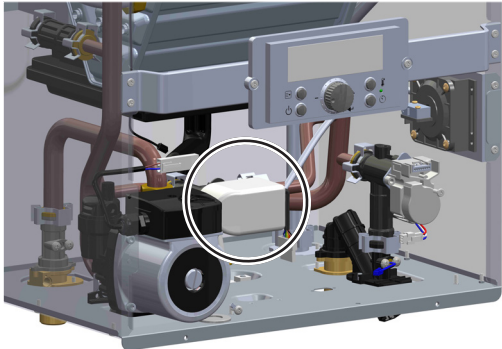
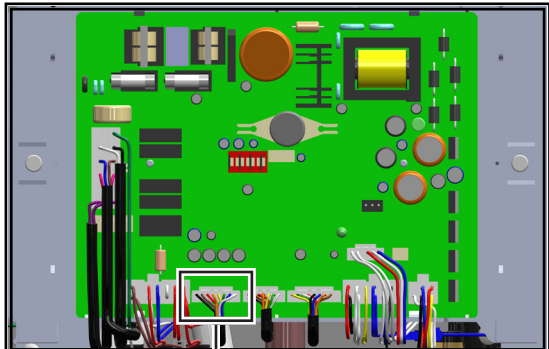
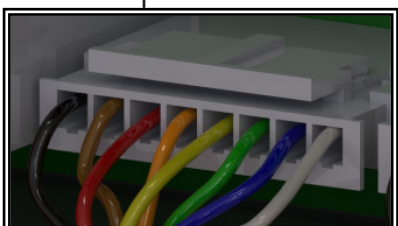
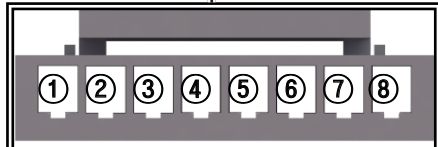
Error code	Meaning	Condition
	<p>Water Mixing Valve Abnormality (Manual restore)</p>	<p>① Occurs manual restore error. ② Water leakage occurs around the water mixing valve. ③ Abnormal valve operation.</p>
Failure event		
<p>Operation of product is stopped once detecting water leakage. The temperature of hot water is not constant.</p>		
Check point		
<div style="display: flex; justify-content: space-between;"> <div style="width: 30%;">   </div> <div style="width: 65%;"> <p>① Check error code sign after turning off and on the power.</p>    </div> </div> <p>[Water Mixing Valve] DHM Y Phase (black) : connector ① DHM Y Phase (brown) : connector ② DHM X Phase (red) : connector ③ DHM X Phase (orange) : connector ④ GND (yellow) : connector ⑤ DHM Position sensor (green) : connector ⑥ Flow2 sensor (blue) : connector ⑦ DC 14V (white) : connector ⑧</p> <p>③ If above ①, ② operates normally replace valve</p>		
<p>④ If above issues operates well replace Circuit Board.</p>		

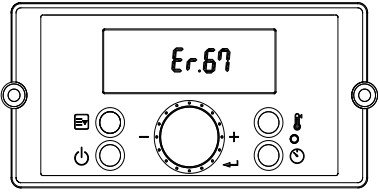
Error code	Meaning	Condition
	<p>AGM Abnormality (Manual restore)</p>	<p>Unable to sense proper positioning of AGM motor, error code 67 will appear.</p>

Failure event

During initialization or AGM check, the AGM motor rotates so that the position can be determined by the circuit board. If there is a discrepancy between the movement of the motor and the circuit board's input (i.e. AGM motor is stuck in one position and cannot rotate), Er. 67 is displayed. Er. 67 must be cleared manually.

Check point

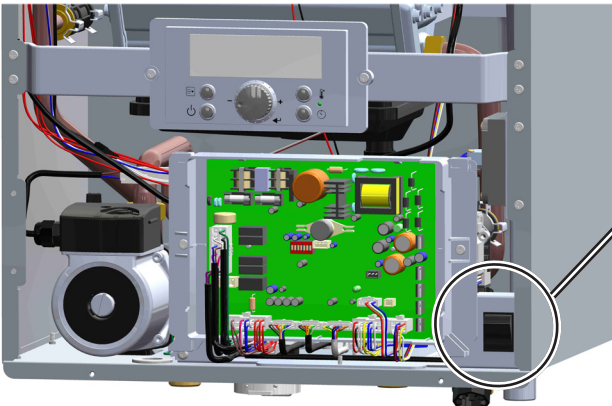

① Check error code sign after turning off and on the power.

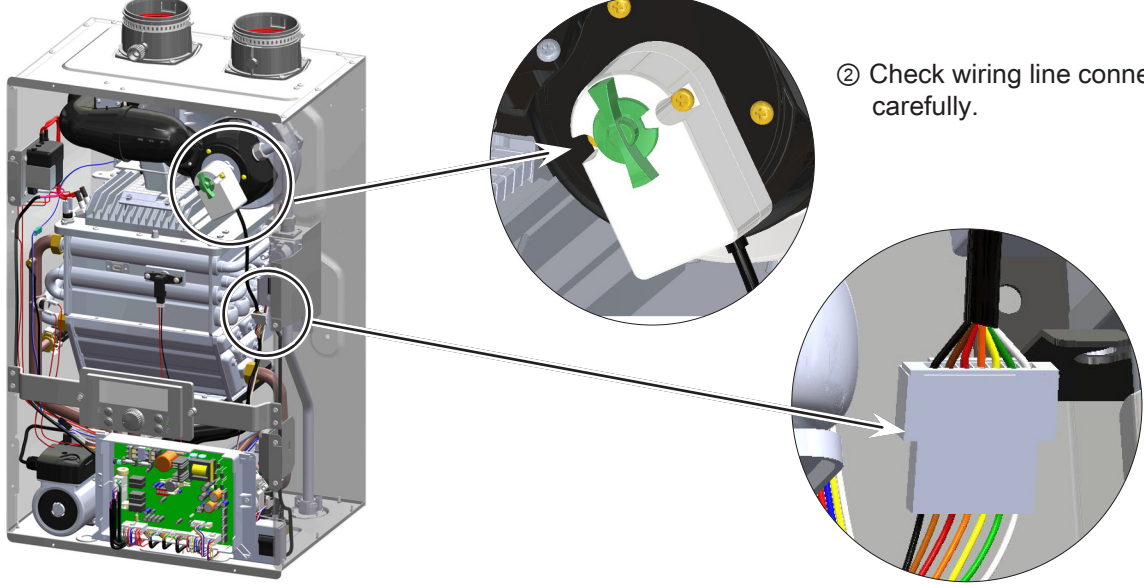

② Check wiring line connection carefully.

- ③ If above ①, ② operates abnormally replace AGM.
- ④ If AGM is moving normally after a hard reset but still doing an Er 67, replace the circuit board with the newest version.

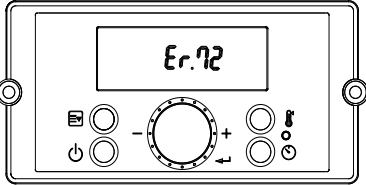
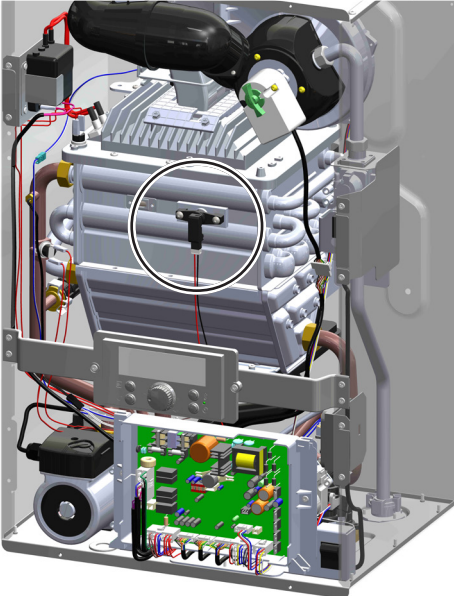
Error code	Meaning	Condition						
	<p>Flame Detected before Igniter Abnormality (Automatic restore)</p>	<p>When detected the flame before ignition, error code 72 will appear.</p>						
<p>Failure event</p>								
<p>When flame detected during no operation then error occurs and s ignition. When flame after pre-purge and then flame is still shown even after pre-purge 10 times then manual restore error occurs. After combustion and post pre-purge is completed but flame is still shown then block ignition sequence performance by occurring error during no operation. Flame detecting error restores automatically when flame disappears.</p>								
<p>Check point</p>								
<p>① Check the front cover will be closed.</p> <p>■ From more than DC 2.5V after ignition safety cut-off will appear</p> <ul style="list-style-type: none"> ① When setting before ignition is less than DC 2.5V : Replace flame sensor. ② When setting before ignition is more than DC 2.5V : Replace the flame observation glass and gasket. <div style="display: flex; align-items: center;">  <table border="1" data-bbox="730 1032 1394 1164"> <thead> <tr> <th>ITEM</th> <th>Normal Value</th> </tr> </thead> <tbody> <tr> <td>Before ignition</td> <td>More than DC 2.5V</td> </tr> <tr> <td>After ignition</td> <td>Less than DC 2.5V</td> </tr> </tbody> </table> </div>			ITEM	Normal Value	Before ignition	More than DC 2.5V	After ignition	Less than DC 2.5V
ITEM	Normal Value							
Before ignition	More than DC 2.5V							
After ignition	Less than DC 2.5V							
<p>② To reset this error code, the power needs to be disconnected and then reconnected.</p>								

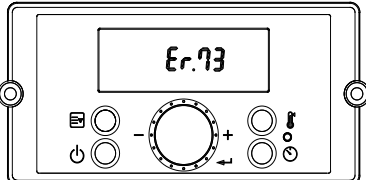
Error code	Meaning	Condition
	DIP Switch Setting Abnormality (Automatic restore)	When Dip switch is set abnormally, error code 73 will appear.

Failure event



This error occurs if the Dip switches on the circuit board are changed or moved when the water heater is plugged into power.

Check point

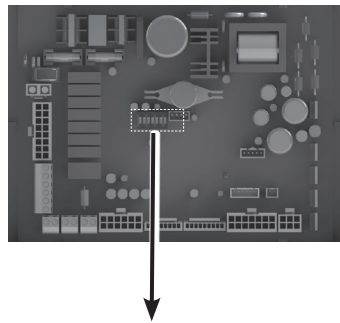
- ① Set accurately by checking capacity on the rating plate attached to the side of water heater and Dip Switch specification listed on the manual.



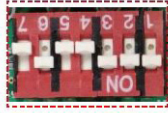
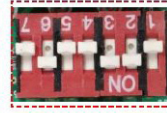
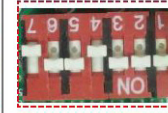

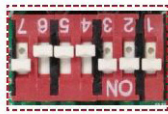
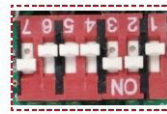
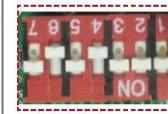
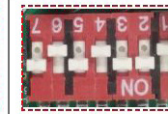
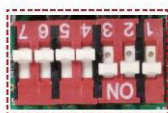
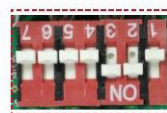
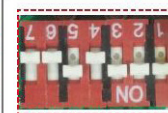
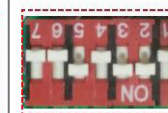
Dip Switch		State	
5	Gas Type	NG : ON	LP:OFF
6	High Fire	6: ON	7: OFF
7	Low Fire	6: OFF	7: ON
6, 7	Normal Fire	6: OFF	7: OFF

Fire	199,000Btu (LP)	180,000Btu (LP)	199,000Btu (NG)	180,000Btu (NG)
High Fire				
Low Fire				
Normal Fire				

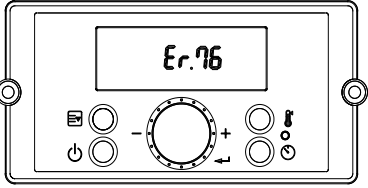
- ② To reset this error code, the power needs to be disconnected and then reconnected.

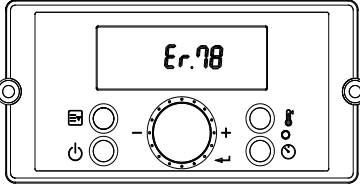
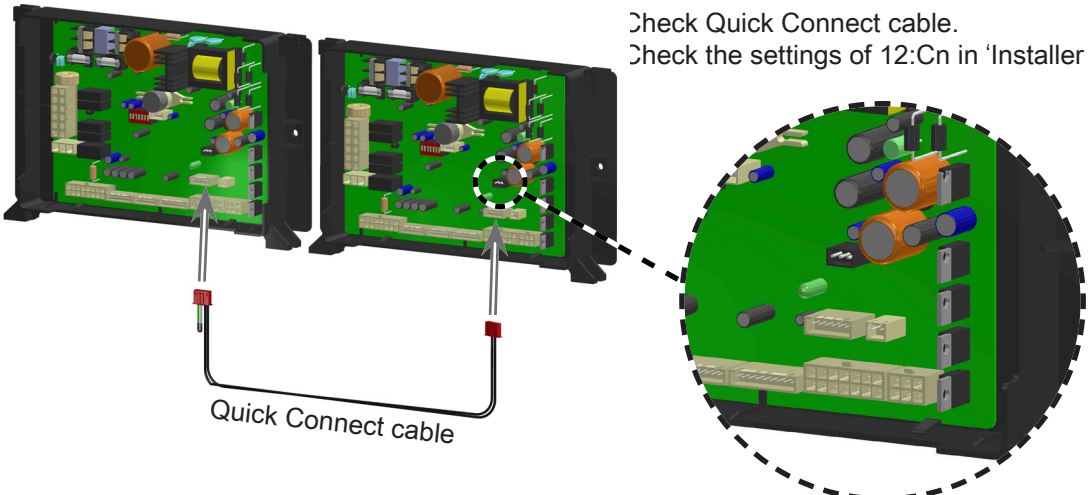
Error	Meaning	Condition
	<p>Communication Error between Control Panel and Circuit Board (Automatic restore)</p>	<p>When communication with display panel is not established for 10 minutes, error code 76 will appear.</p>
Fault		
<p>Connection error between control panel and circuit board.</p>		
Check point		
<p>① Check connections from circuit board to Control Panel. ② To reset this error code, the power needs to be disconnected and then reconnected.</p>		

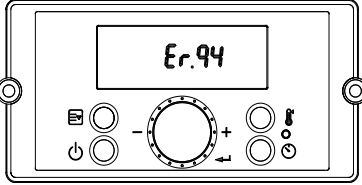
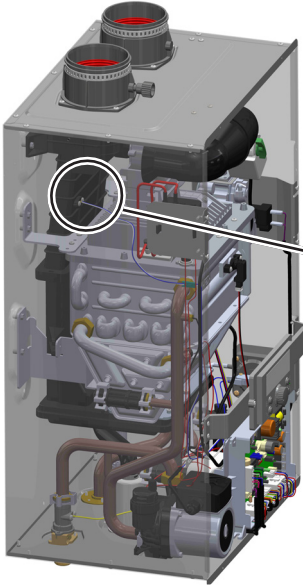
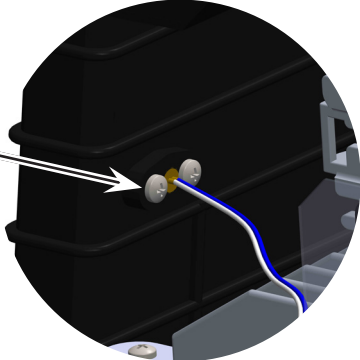
Error	Meaning	Condition
	<p>Cascade Communication Abnormality</p>	<p>When the unit operating is stopped, error code 78 occurred.</p>
<p>Failure event</p>		
<p>Under 'Cascade communication failure', 'Setting error', 'Back flow of the Exhausted Gas' and 'Gas Leak', Er78 occurred.</p>		
<p>Check point</p>		
<div style="display: flex; align-items: center;">  <div style="margin-left: 20px;"> <p>Check Quick Connect cable. Check the settings of 12:Cn in 'Installer Mode'.</p> </div> </div>		
<p>③ When Er40(Gas Leak), Er61(Fan error) or Er67(AGM error) have occurred, Cascade Communication error (Er78) occurs to protect 'Back Flow' of the exhausted gas.</p> <p>In case of Er45(Water Leak), both units shut down to minimize the property damage due to an internal leak.</p> <p>④ Check that one of the above errors is occurred.</p>		

Error code	Meaning	Condition
	<p>Exhaust temperature exceeds selected cutoff temperature. (Manual restore)</p>	<p>Overheating Exhaust Thermistor (The water heater shuts down when the exhaust temperature exceeds 149°F (65°C).)</p>
<p>Failure event</p>		
<p>It occurs when exhaust gas emission is faulty due to exhaust flue blockage. When excessive amount of gas inflows due to higher set of dip switch than its hot water heater capacity, exhaust gas temperature will increase more than excess temperature. Exhaust gas temperature may be high due to heat exchanger's malfunction.</p>		
<p>Check point</p>		
<p>① Turn off the water heater for at least 30 minutes, and then restart it.</p>		
	<p>② Check Exhaust Thermistor's wiring connected at exhaust duct is disconnected. And check circuit boards socket. (CN7 : White ⑤, Blue ⑫)</p>	
	<p>③ Check for any obstructions in the vent pipe.</p>	

Main components Replacement Instructions

1. Circuit Board

1. Close the gas shut off valve and water valve.
2. Turn the power on.
3. Enter 'Installer Mode', 'Status Mode' from control panel. (See page 44,45)
4. On a piece of paper, write down the factory settings in the 'Installer Mode' for 4:FH,5:FL,'Status Mode' J:AG. These numbers MUST be recorded before the old circuit board is removed, the valves are specific to the unit.
5. Turn the power off water heater. (Use the manual switch)
6. Unplug connectors on Circuit board.

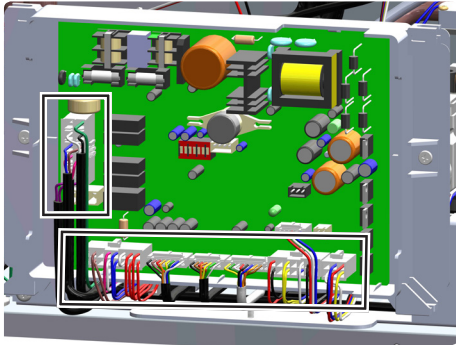

7. Loosen two screws to remove Circuit board.

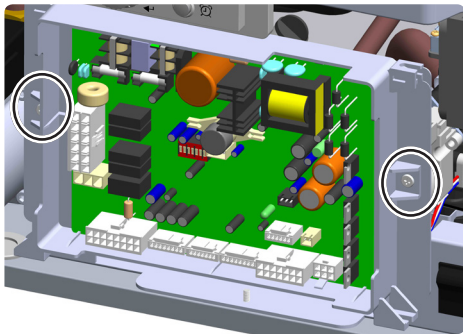

8. Remove the circuit board and replace with new circuit board.
9. Reconnect all wire connections to the new circuit board.
10. Verify the dip switch settings are correct on the new circuit board. (See normal fire in figure below)
11. Open the gas shut off valve.
12. Open all water valves.

Fire	199,000Btu (LP)	180,000Btu (LP)	199,000Btu (NG)	180,000Btu (NG)
High Fire				
Low Fire				
Normal Fire				

13. Turn the power on. (Use the manual switch)
14. Enter 'Installer Mode', 'Status Mode' from control panel.
15. Set the values for 4:FH,5:FL,J:AG. (These are the numbers you wrote down in Step 4)
16. Save the values for 4:FH,5:FL,J:AG.
17. Turn the unit on and ensure proper operation.
18. Test operation.

If carbon dioxide and manifold pressure values are matched with Table 1 in the low fire combustion, switch dip switch from low to high fire and check carbon dioxide and manifold pressure values. If the values are matched with Table 1, shut off the unit and close the gas valve. Then disconnect the hose that is connected to the manifold pressure port, then tighten the screw for the manifold pressure port, and return the dipswitch back to normal condition. Finally, close the front cover.

NOTE

When assemble connector, check wiring color and locations to avoid any mistakes.

Table 1

Manifold pressure (±0.01")	'LP' type		'NG' type		
	2" VENT	3" VENT	2" VENT	3" VENT	
199,000 Btu/hr	High fire	-0.3" W.C	-0.25" W.C	-0.38" W.C	-0.33" W.C
	Low fire	-0.02" W.C	-0.02" W.C	-0.07" W.C	-0.07" W.C
180,000 Btu/hr	High fire	-0.28" W.C	-0.23" W.C	-0.36" W.C	-0.31" W.C
	Low fire	-0.02" W.C	-0.02" W.C	-0.07" W.C	-0.07" W.C

Dip Switch		State	
5	Gas Type	NG : ON	LP:OFF
6	High Fire	6: ON	7: OFF
7	Low Fire	6: OFF	7: ON
6, 7	Normal Fire	6: OFF	7: OFF

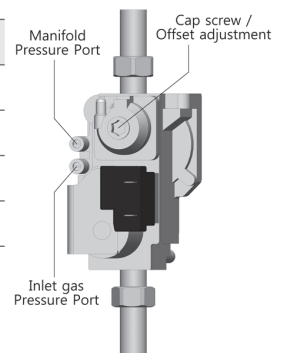

Main components Replacement Instructions

2. Igniter

1. Close the gas shut off valve
2. Turn the power off.
3. Disconnect the wiring to the igniter.

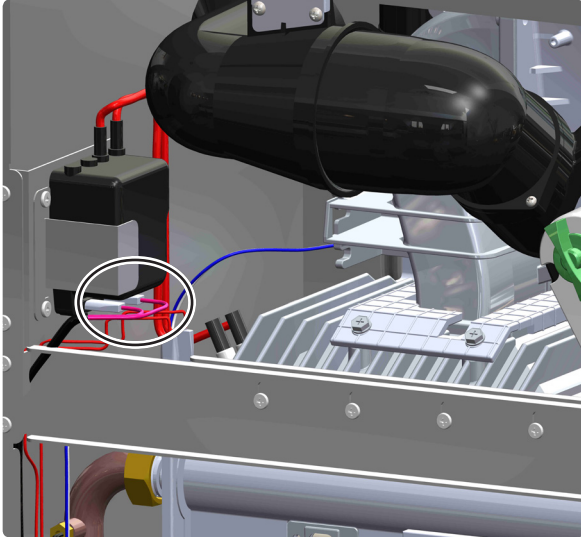

4. Remove the cable connected to the ignition plug.

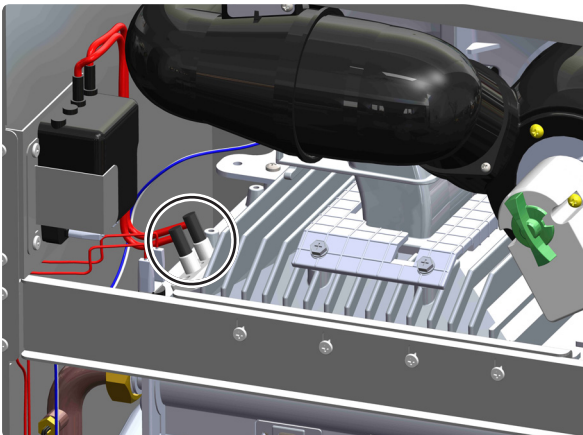

5. Loosen two screws to separate igniter from the water heater cabinet.

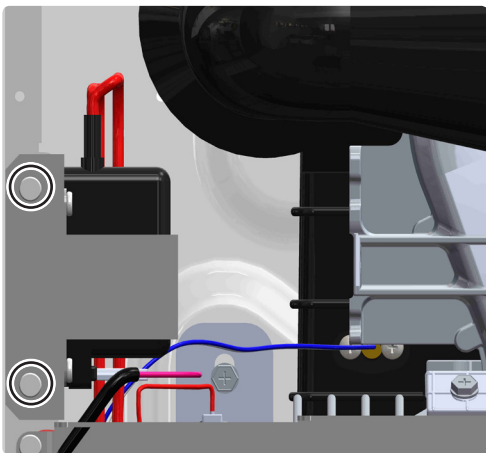

6. Loosen two screws to separate igniter from the bracket.

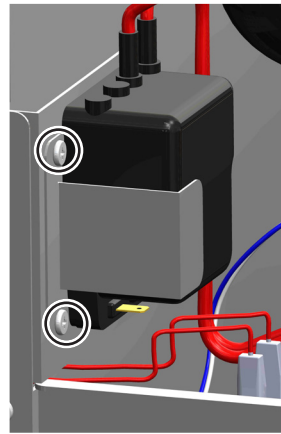

7. Separate igniter from bracket by unlocking the plastic tabs on the back side of the bracket.

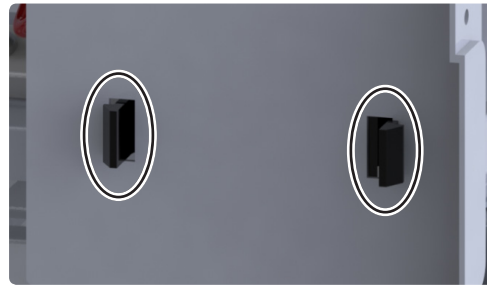

8. Replace igniter with new component.
9. Assemble in the reverse order as the part was removed.
10. Open the gas shut off valve.
11. Turn the power on.
12. Turn the unit on and ensure proper operation.

NOTE

1. Ensure the igniter is properly secured.

Main components Replacement Instructions

3. Flame Detection Sensor

1. Close the gas shut off valve.
2. Turn the power off.
3. Disconnect the electrical connection to the flame detection sensor.
(Push and hold the button on the back side of the connection to remove.)

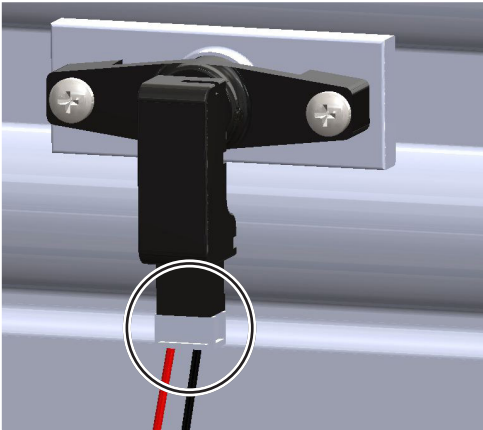

4. Rotate flame detection sensor 45 degrees clockwise and pull forward.

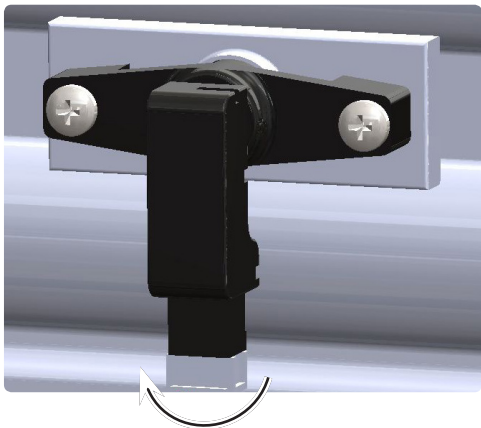

5. Replace flame detection sensor with new component.
6. Assemble in the reverse order as the part was removed.
7. Open the gas shut off valve.
8. Turn the power on.
9. Turn the unit on and ensure proper operation.

NOTE

1. Check fixed condition of the part.

4. Gas Leak Detector

1. Close the gas shut off valve.
2. Turn the power off.
3. By using a hand screwdriver, remove 4 screws of the front cover.
4. Disconnect all the electrical connection to the circuit board.

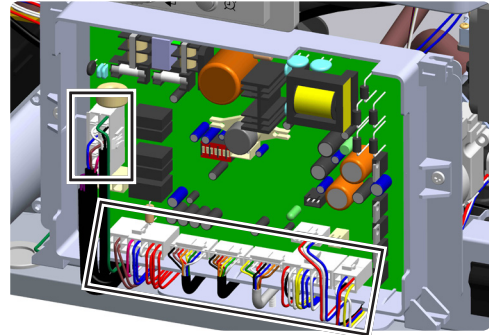

5. Loosen two screws to remove the circuit board.

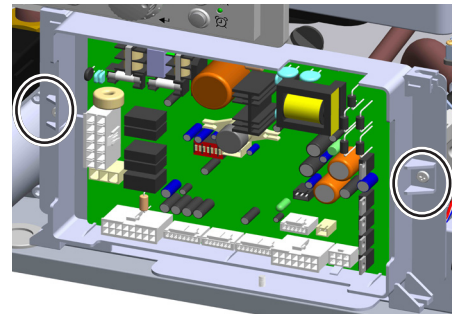

6. Replace the circuit board with new component.
7. Assemble in the reverse order as the part was removed.
8. Assemble connectors on circuit board.
9. Open the gas shut off valve
10. Turn the power on.
11. Turn back the water valve in the opening direction.
12. Test operation. (Please refer to page 81 for combustion characteristics test.)

Main components Replacement Instructions

5. Air Pressure Switch

1. Close the gas shut off valve.
2. Turn the power off.
3. Disconnect the electrical connection to the APS.

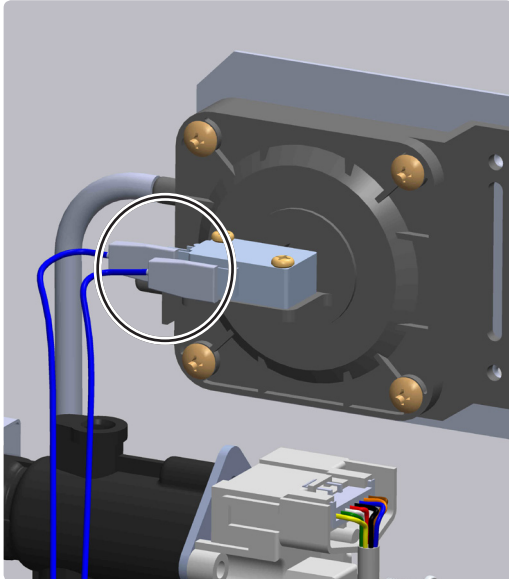

4. Separate hose from air pressure switch.

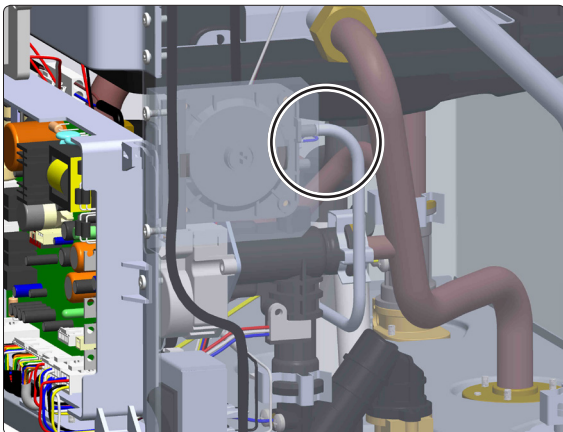

5. Loosen bracket's two screws and separate air pressure switch from the cabinet.

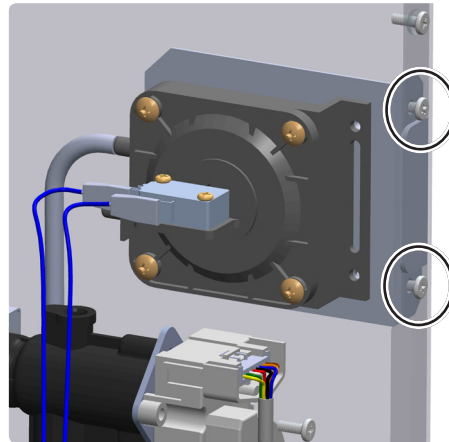

6. Replace air pressure switch with new component.
7. Assemble in the reverse order as the part was removed.
8. Open the gas shut off valve.
9. Turn the power on.
10. Open water valves (Hot water and DHW)
11. Turn the unit on and ensure proper operation.

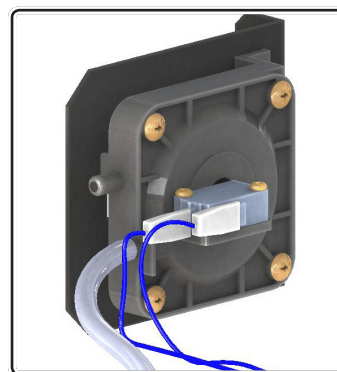

Connect a hose to the connector marked 'H' character.

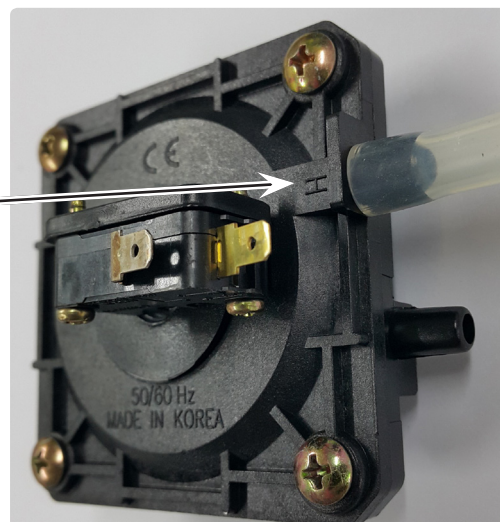
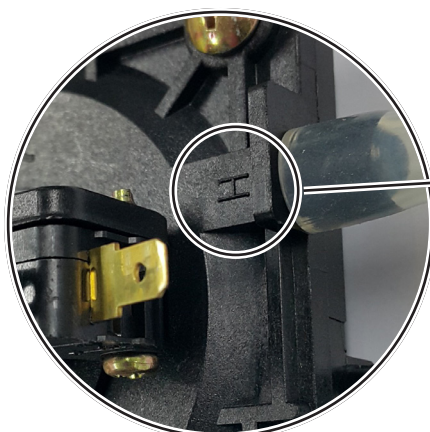

Main components Replacement Instructions

6. Gas Valve

1. Close the gas shut off valve.
2. Turn the power off.
3. Close all water valve (Hot water and DHW)
4. Loosen the fastened screws of the case front bracket.

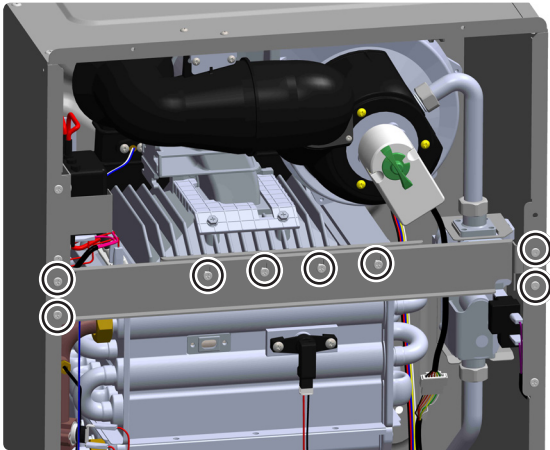

6. Disconnect the electrical connection to the gas valve.

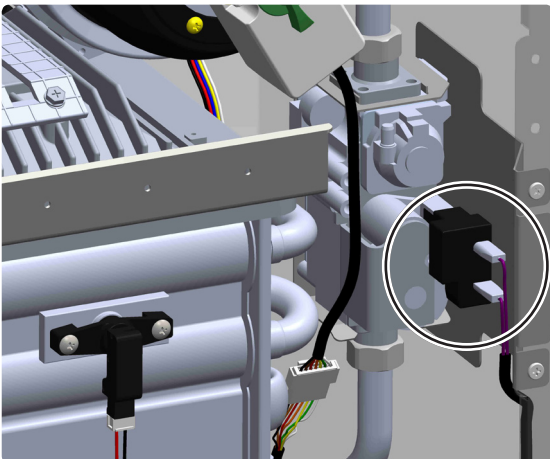

7. Loosen the nuts as shown.

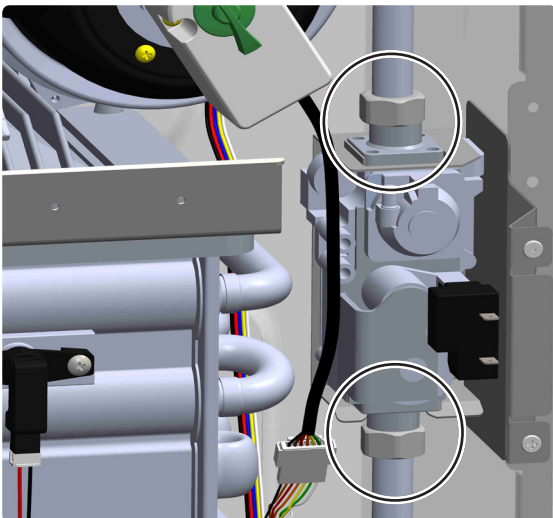

8. Remove the bracket's two screws and separate gas valve from the cabinet.

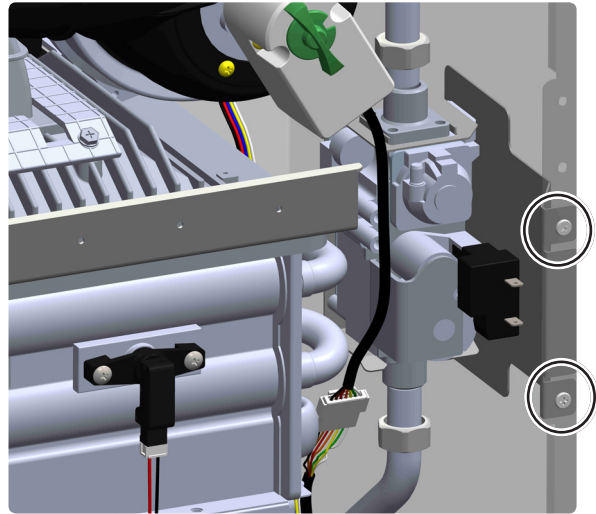

9. Replace the gas valve with new component. Check the o-rings for damage, if damaged, replace with new o-rings.
10. Assemble in the reverse order as the part was removed.
11. Open the gas shut off valve.
12. Turn the power on.
13. Open water valves (Hot water and DHW)
14. Turn the unit on and ensure proper operation.

NOTE

1. Replace it with the new gas valve.
2. Check wire condition connected to gas valve.
3. Make sure the packing is inserted correctly when assembling the nuts.
4. Compare to the manifold pressure with pressure indicated at the rating plate after connecting gas valve.
5. Check for gas leaks after reinstalling new gas valve.

Main components Replacement Instructions

7. Flow Control Valve

1. Close the gas shut off valve.
2. Turn the power off.
3. Place a bucket under the unit and rag under valve to collect the residual water from the water heater.
4. Disconnect the electrical power to the water heater.
5. Close the both DHW inlet and hot water valve.
6. Open the Hot water faucets completely.
7. Disconnect all the electrical connection to the circuit board. Loosen the three screws to remove the Circuit Board and Circuit Board Bracket in one piece.

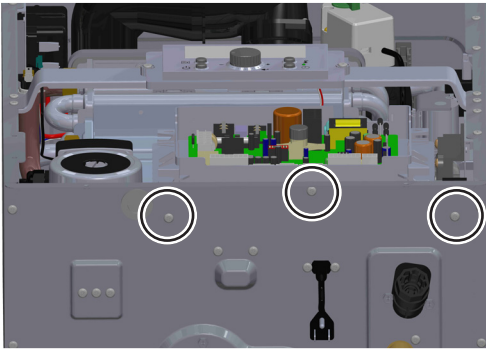

8. Remove two clips connected to the Flow Control Valve and remove the wire connection to the Flow Control Valve.

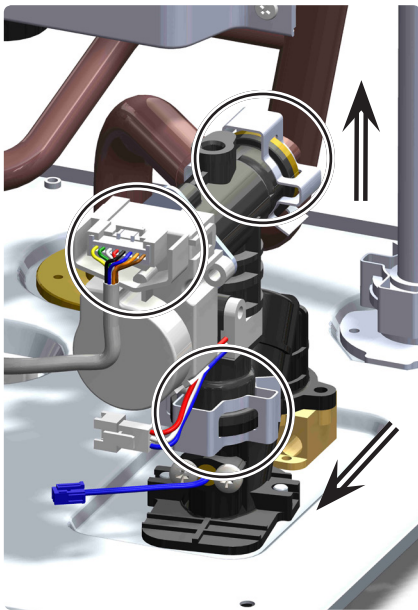

9. Loosen this nut from HEX pipe.

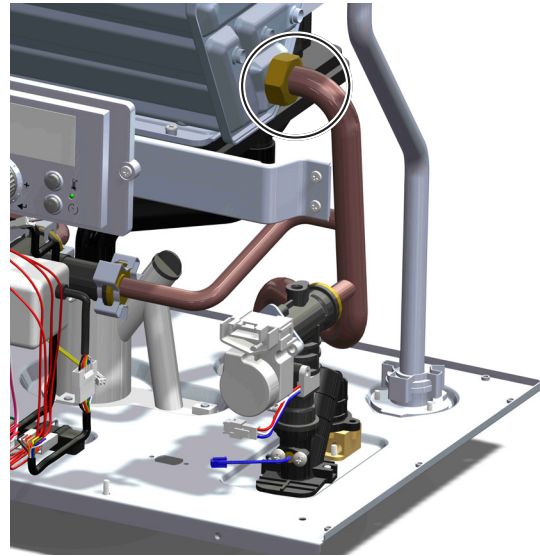

10. Remove the flow valve in the direction of the arrow.

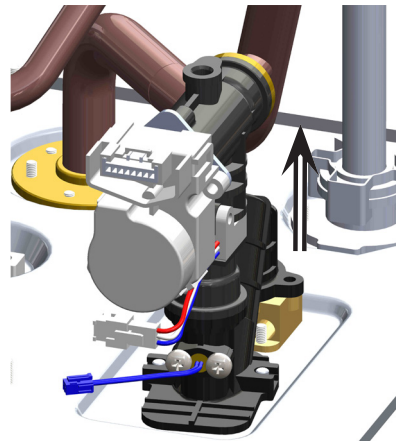

11. Replace the Flow Control Valve with new spare part. Check the o-rings for damage, if damaged, replace with new o-rings.
12. Assemble in the reverse order as the part was removed.
13. Open the gas shut off valve.
14. Turn the power on.
15. Open water valves (Hot water and DHW).
16. Turn the unit on and ensure proper operation.

NOTE

1. Check wire condition connected to flow valve.
2. Make sure the o-ring is inserted correctly when assembling the pipe.

Main components Replacement Instructions

8. Water Mixing Valve

1. Close the gas shut off valve.
2. Turn the power off.
3. Place a bucket under the unit and rag under valve to collect the residual water from the water heater.
4. Disconnect the electrical power to the water heater.
5. Close the both DHW inlet and hot water valve.
6. Open the Hot water faucets completely.
7. Disconnect all the electrical connection to the circuit board. Loosen the three screws to remove the Circuit Board and Circuit Board Bracket in one piece.

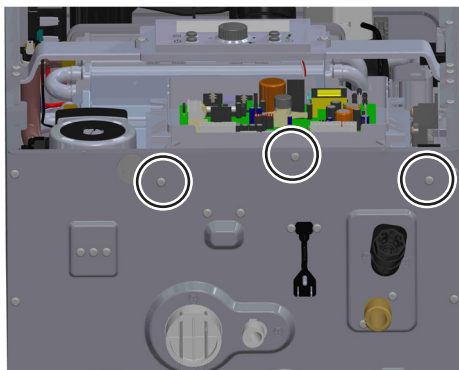

8. Separate connector connected with water mixing valve.
9. Remove two clips connected with water mixing valve and outlet pipe.

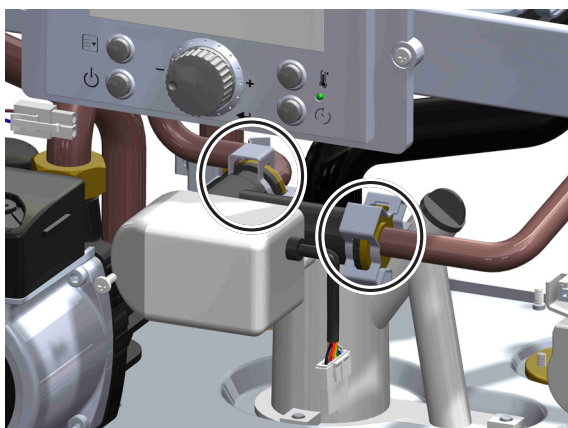

10. Separate water mixing valve and outlet pipe.

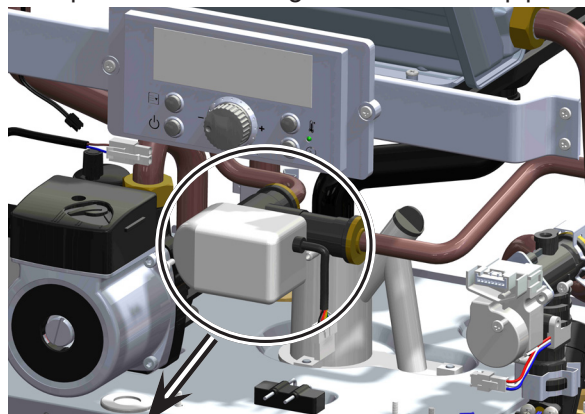

11. Remove the water mixing valve and replace with new spare part. Check the o-rings for damage, if damaged, replace with new o-rings.
12. Assemble in the reverse order as the part was removed.
13. Switch water valve to open.
14. Switch manual power switch to open.
15. Switch main gas valve to open.
16. Test operation.

Main components Replacement Instructions

9. Circulation Pump

1. Close the gas shut off valve.
2. Turn the power off.
3. Place a bucket under the unit and rag around pump to collect the residual water from the water heater.
4. Disconnect the electrical power to the water heater.
5. Close the DHW inlet valve.
6. Drain water from the hot water & DHW loop.
7. Remove wire connector connected to circulation pump.
8. Loosen the nut on the pump and HEX pipe, loosen wire tie.

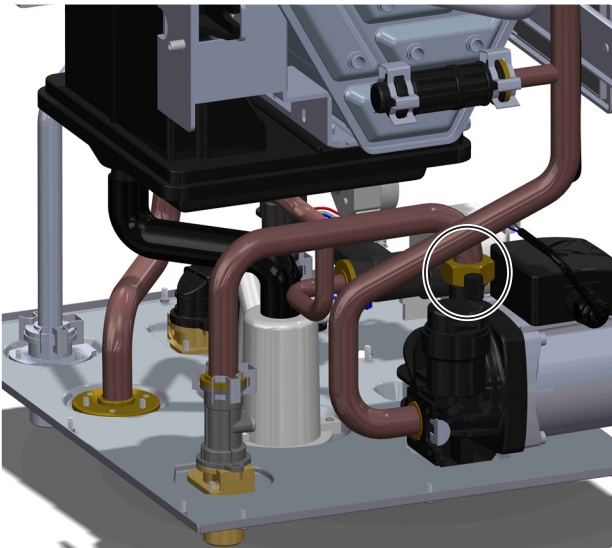

And disconnect the connector for High Limit Switch and HEX Thermistor.

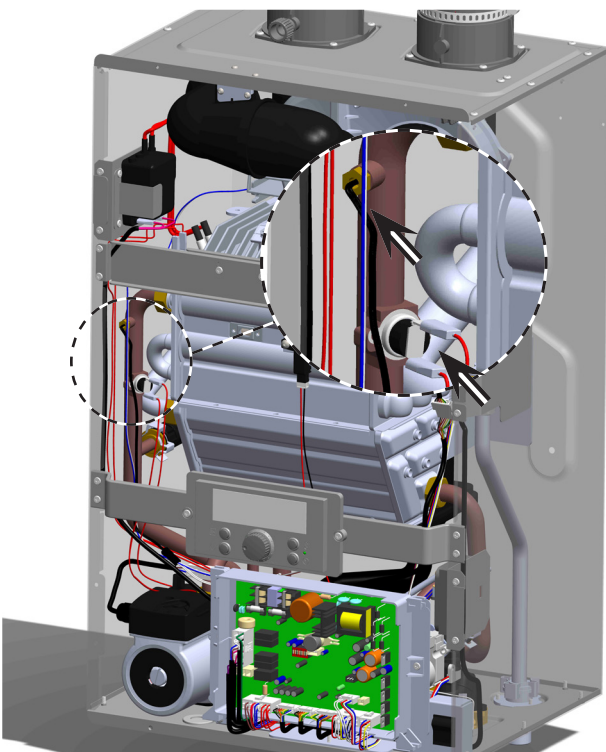

9. Using a hand screwdriver, remove three screws on the pump fixing bracket and remove the clip to separate pump from the HEX water pipe.

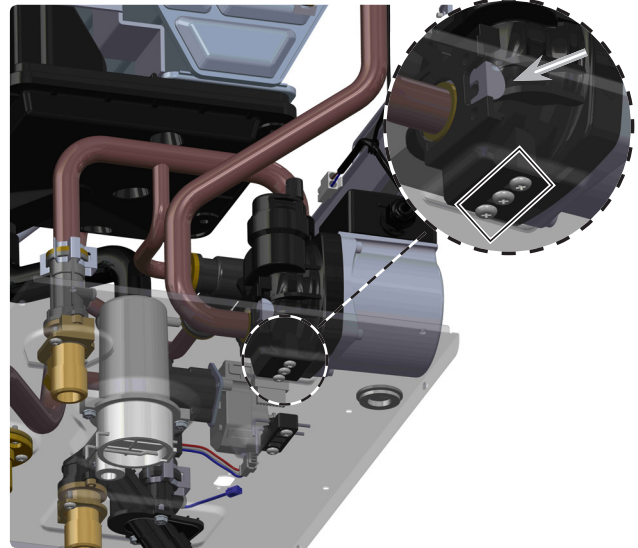

10. Remove the circulation pump with the HEX water pipe in the direction of the arrow.

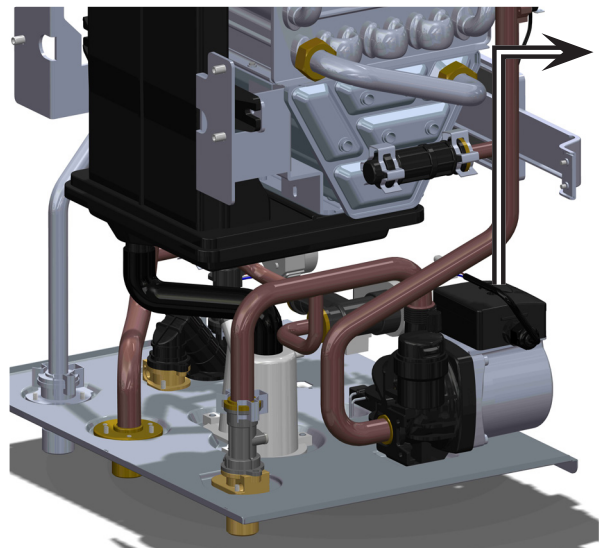

11. Remove HEX water pipe from the pump.
12. Replace the pump with new part. Check the o-rings for damage, if damaged, replace with new o-rings.
13. Assemble in the reverse order as the part was removed.
14. Open the gas shut off valve.
15. Turn the power on.
16. Open water valves (Hot water and DHW).
17. Turn the unit on and ensure proper operation.

NOTE

1. Check wire condition connected to pump.
2. Make sure the o-ring is inserted correctly when assembling the pipe.

Main components Replacement Instructions

10. AGM

1. Close the gas shut off valve.
2. Turn the power off.
3. Close all water valve (Hot water and DHW)
4. Disconnect the electrical connection to the AGM.

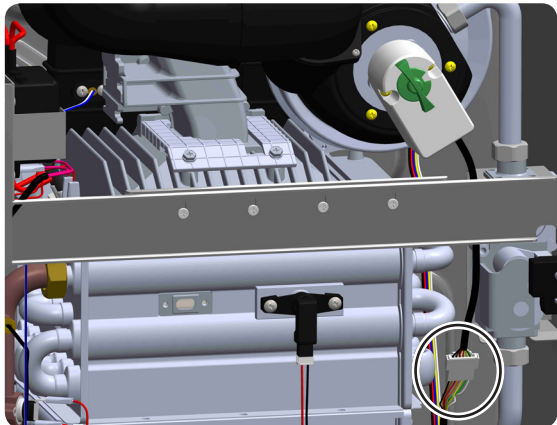

5. By using a hand screwdriver, remove 2 screws of the AGM.

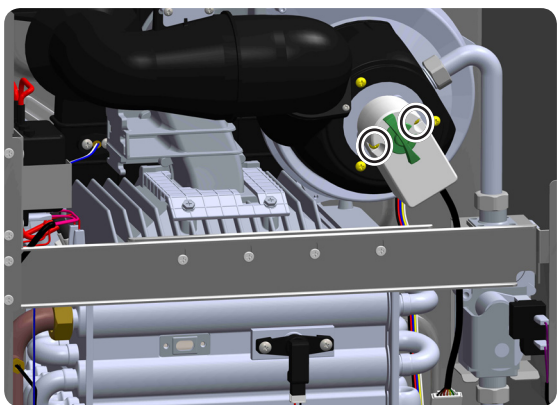

6. Replace AGM with new component.
7. Assemble in the reverse order as the part was removed.
8. Open the gas shut off valve.
9. Turn the power on.
10. Open water valves (Hot water and DHW)
11. Turn the unit on and ensure proper operation.

NOTE

AGM comes with the Gas Mixer Body, if the Gas Mixer Body is damaged, replace it, otherwise this part is not used.

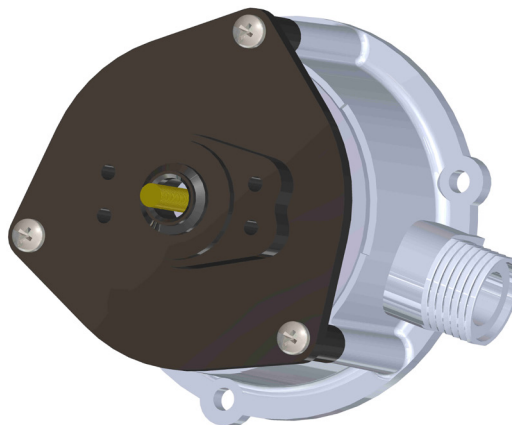

■ Warning : AGM Mounting Position.



Main components Replacement Instructions

11. Fan Assembly

1. Close the gas shut off valve.
2. Turn the power off.
3. Close all water valve (Hot water and DHW)
4. Disconnect the electrical connection to the AGM.
5. By using a hand screwdriver, remove 2 screws of the AGM.

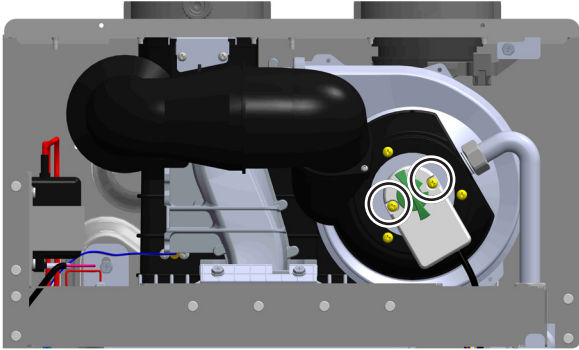

6. Remove 3 screws of the air intake pipe and loosen gas pipe nut.

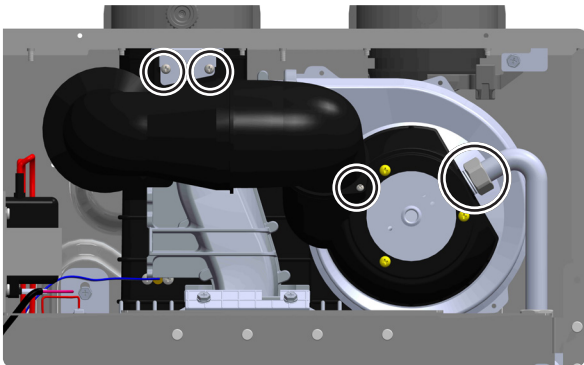

7. Loosen burner head bracket's 2 screws and separate from burner.

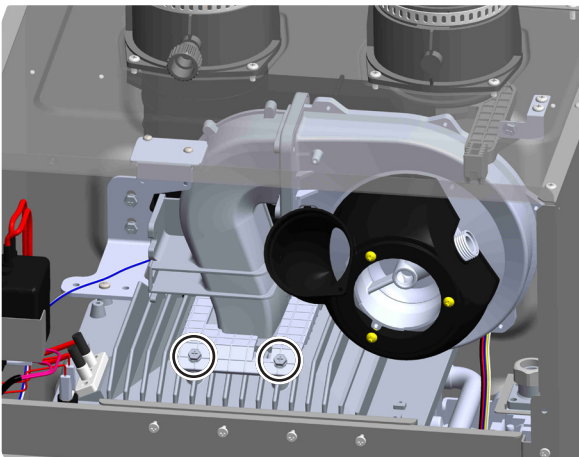

8. Remove 3 screws of the AGM plate.

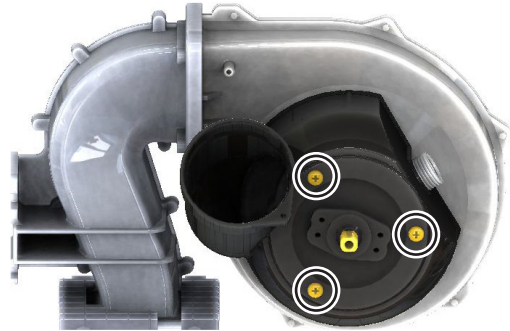

9. Using a hand screw driver or crescent wrench, remove the 4 screws to the Fan assembly.

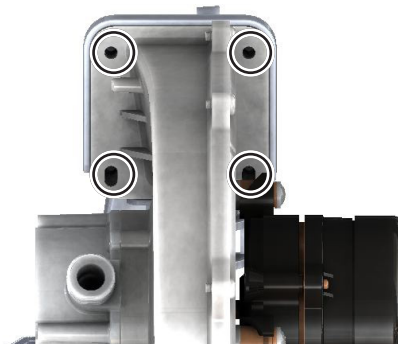

10. Replace the gas valve with new part. Check the o-rings for damage, if damaged, replace with new o-rings.

11. Assemble in the reverse order as the part was removed.

12. Open the gas shut off valve.

13. Turn the power on.

14. Open water valves (Hot water and DHW)

15. Turn the unit on and ensure proper operation.

Main components Replacement Instructions

12. Heat Exchanger

1. Close the gas shut off valve.
2. Turn the power on/off button "On".
3. Turn and leave open the hot water fixtures/ faucets for more than 2 minute and close.
- * An 11 Error Code may appear on the control panel. This is not a malfunction of the unit. Do not turn Power ON/OFF Button OFF.
4. Close the water supply valve and disconnect the electrical power supplied to the unit.
5. Fully open all hot water fixtures/faucets.
6. Open all drain plugs and drain the water out of the unit.
7. When the water is completely drained, replace all drain plugs and close the hot water fixtures/faucets.

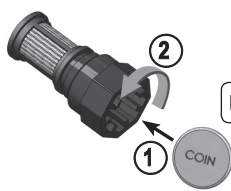
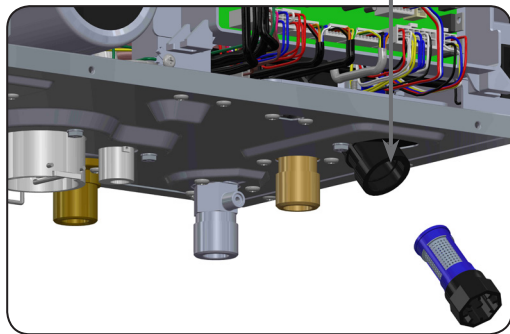
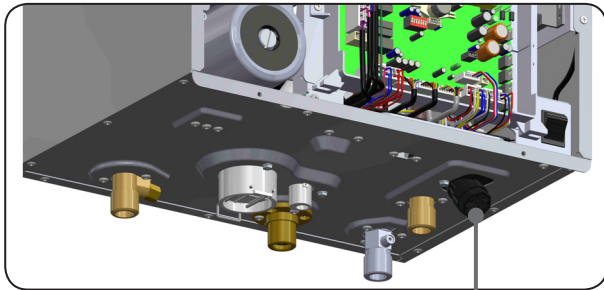

Cold Water Filter

Use a coin.

8. Remove Control Panel from water heater case. (Disconnect the wires to the Control Panel. Loosen four screws to remove Control Panel & bracket.)

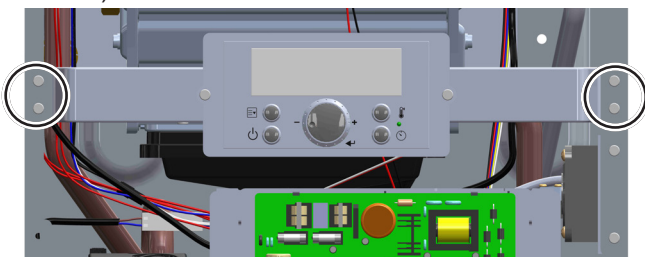

9. Unplug wire connectors that attach to the wiring harness.(Burner Overheat switch, Ignition plug)

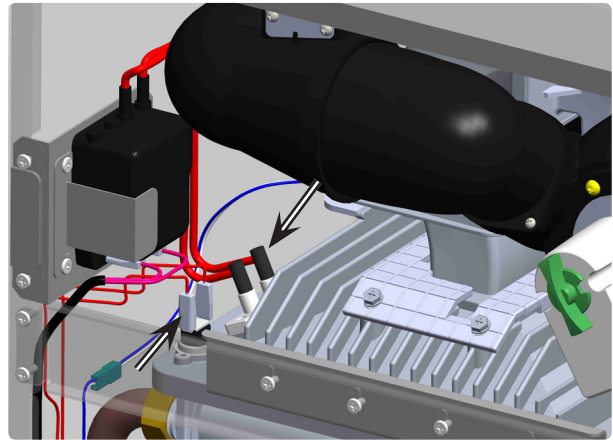

10. Loosen the fastened screws of the case front bracket.

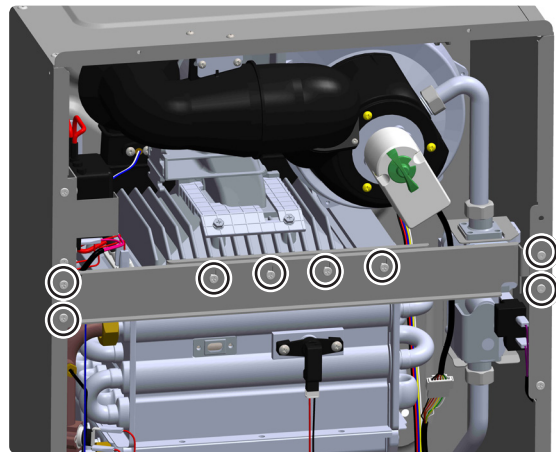

11. Remove Flame Detector connector.

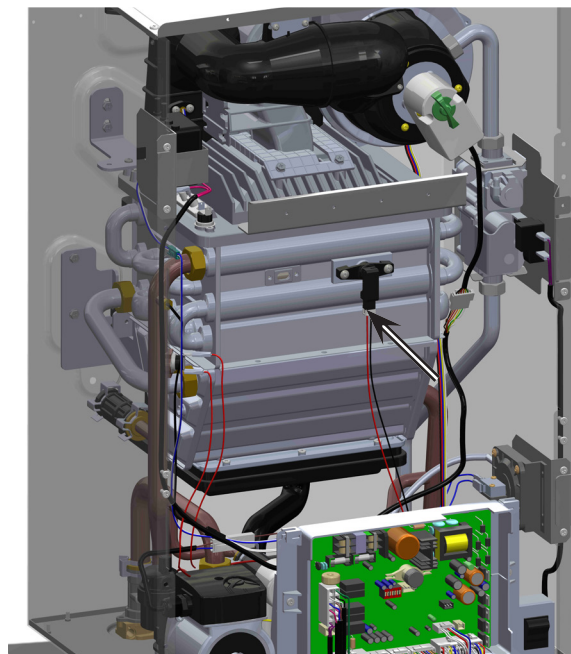

Main components Replacement Instructions

- 11. Unplug connectors on Circuit Board.
- 12. Loosen the three screws to remove the Circuit Board and Circuit Board Bracket as one piece.

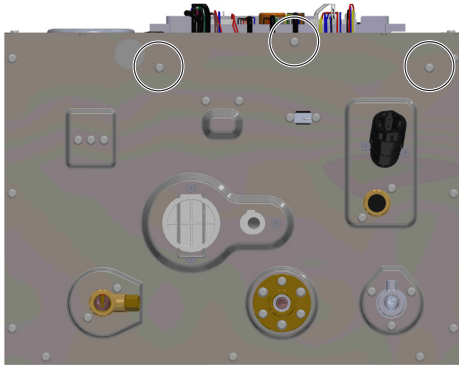

- 13. Remove two clips and then pull out the Condensate Hose.

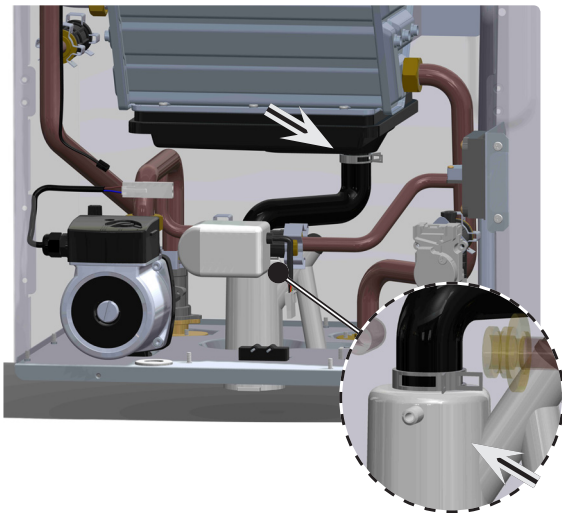

- 14. Remove the Fan assembly.
- 1) Remove AGM connector.

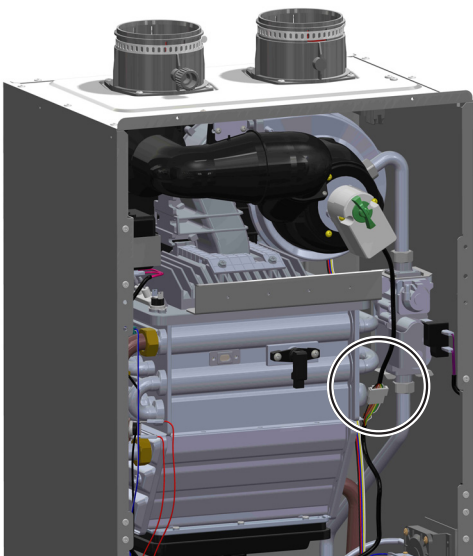

- 2) Remove Fan connector.



- 3) Loosen three screws to remove air pipe. Separate intake pipe attached to AGM.

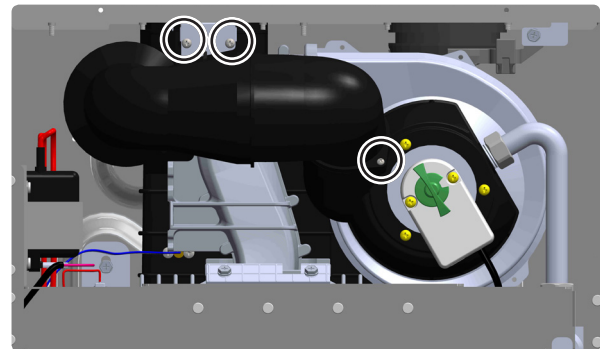

- 4) Loosen gas pipe nut connected with AGM. By using a hand screwdriver, remove 2 screws of the AGM.

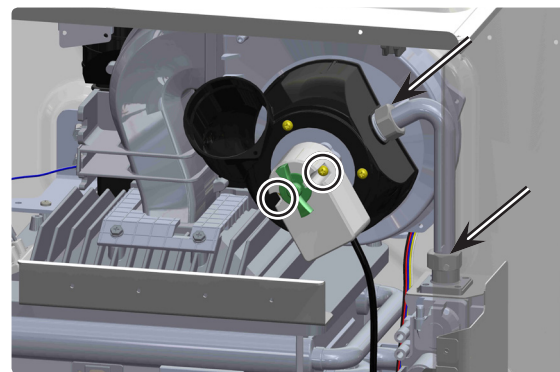

- 5) Loosen burner plate bracket's by loosen two screws as shown.

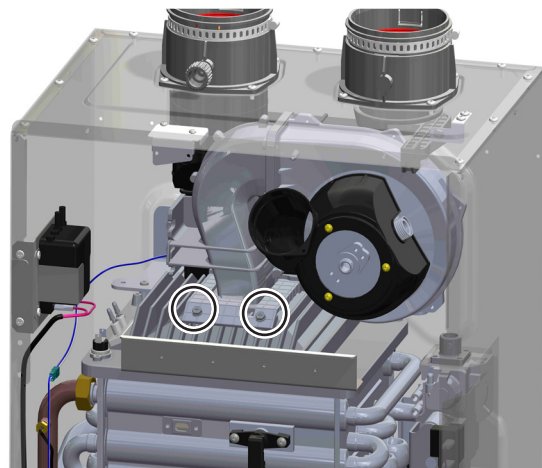

Main components Replacement Instructions

6) Remove the Fan assembly in the direction of the arrow.

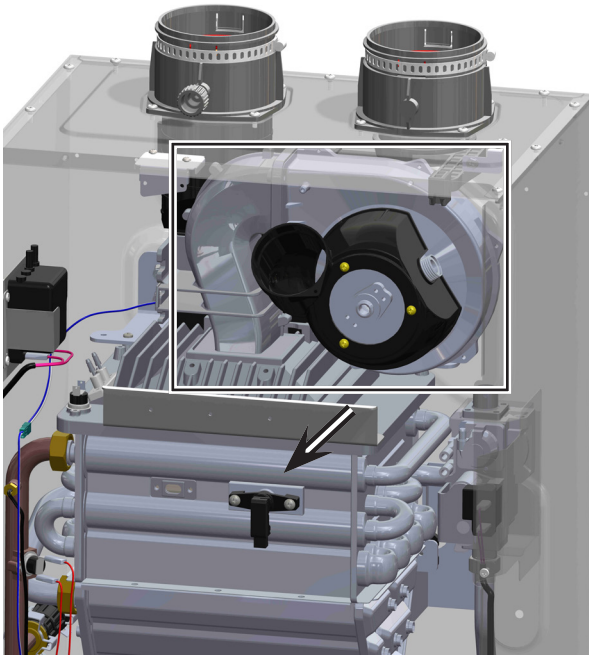

15. Loosen water pipe nut connected with Heat Exchanger.

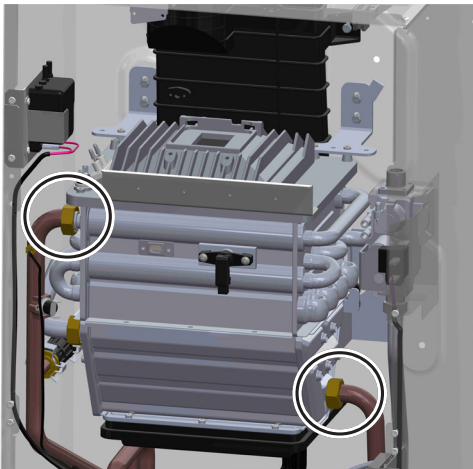

16. Remove four screws on the top of case.

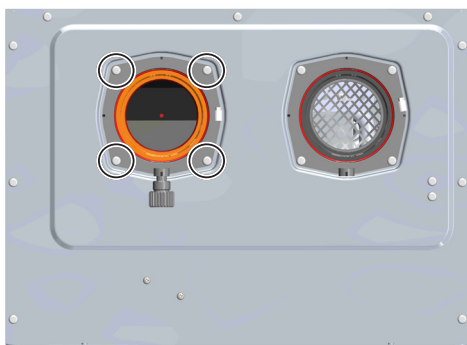

17. Loosen ten screws to remove Heat Exchanger. Pull out the Heat Exchanger inside case.

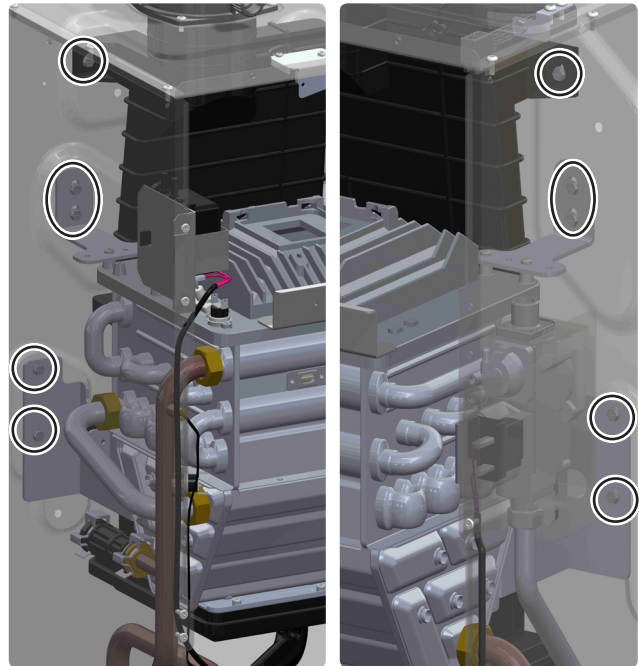

18. Disassemble the screws of the disassembled heat exchanger and assembled bracket to remove the bracket. Replace the Heat Exchanger assembly with the Burner and Exhaust Pipe. Check the o-rings for damage, if damaged, replace with new o-rings.

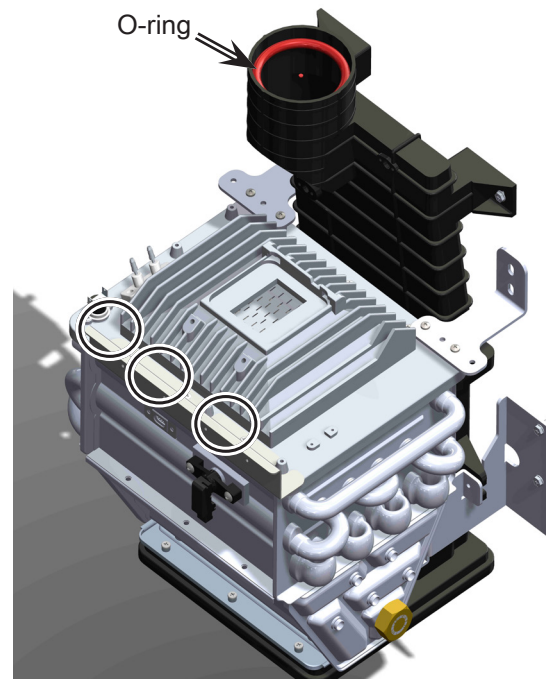

19. Assemble in the reverse order as the part was removed.

20. Open the gas shut off valve.

21. Open all water valves.

22. Turn the power on. (Use the manual switch)

23. Turn the unit on and ensure proper operation.

1. Cleaning the Water Heater

1. Cleaning Air Intake Filter

To properly maintain the water heater, you should check air intake filter every month. If not, you will encounter a problem with combustion specifications.

To clean air intake filter:

- 1. Press the Power button on the control panel to turn off the water heater.
- 2. Disconnect the power supply from the water heater.
- 3. If the water heater has been operating, wait for it to cool l

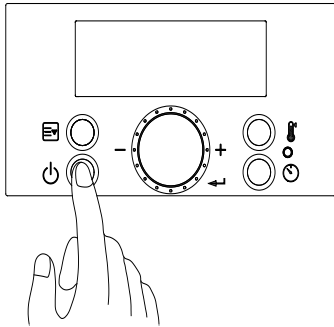

- 4. Remove the 4 screws on the front cover of the water heater.

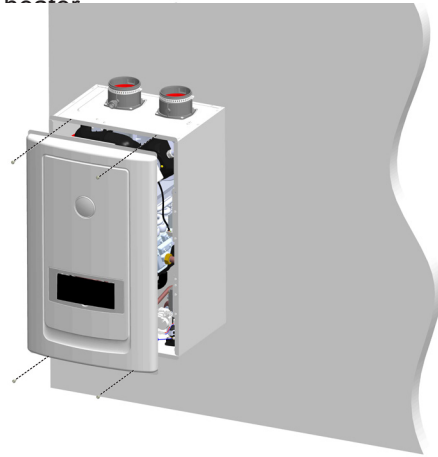

- 5. Remove the filter screen screw and pull the filter out of the air intake adapter.

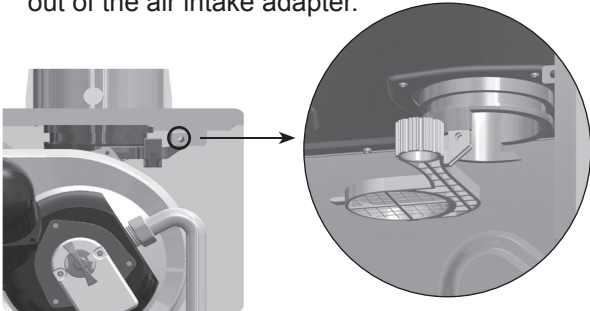

- 6. Clean it with a toothbrush and clean running water.



- 7. Dry the filter completely. Then reinsert the filter into the plastic assembly and tighten the filter screen screw.
- 8. Replace the front cover of the water heater cabinet. Reconnect power supply to the water heater.
- 9. Press the Power button on the control panel to turn on the water heater.

2. When supplying combustion air from the indoors.

To clean air supply vent:

Check for debris or blockage from dust, oil, etc. at the air supply vent. If blocked, remove the build-up with a vacuum cleaner or damp towel. (Do not permanently remove the inlet screen.)

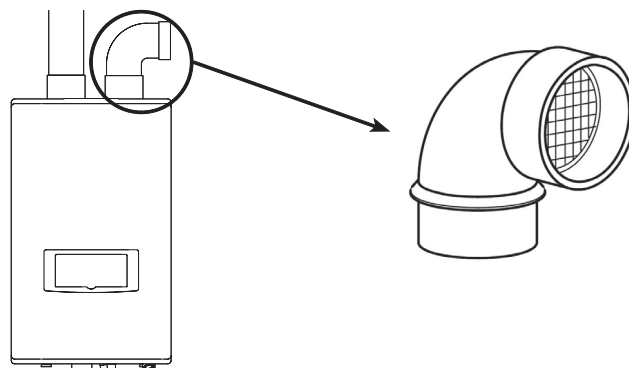

2. Maintenance Procedures

DANGER

The water heater must be inspected and serviced annually, preferably at the start of the heating season, by a qualified service technician. In addition, the maintenance and care of the water heater as outlined in this manual must be performed by the user/owner to assure maximum efficiency and reliability. Follow the maintenance procedures given throughout this manual. Failure to perform the service and maintenance or follow the directions in this manual could damage the water heater or system components, resulting in substantial property damage, severe personal injury, or death.

DANGER

To prevent the potential of substantial property damage, severe personal injury, or death, eliminate all the materials listed in Table 1 from the area surrounding the water heater and the vicinity of the combustion air intake. If contaminants are found:

- Remove products immediately from area.
- If contaminants have been there for an extended period, call a qualified service technician to inspect the water heater for possible damage from acid corrosion.

If products cannot be removed, immediately call a qualified service technician to re-pipe the combustion air intake piping away from the contaminated areas.

Combustible/Flammable Materials

Do not store combustible materials, gasoline, or other flammable vapors or liquids near the water heater. If found, remove these materials immediately.

Air Contaminates

If allowed to contaminate combustion air, products containing chlorine or fluorine will produce acidic condensate that will cause significant damage to the water heater. Read the list of potential contaminants and areas likely to have these contaminants in Table 1. If any of these contaminants are in the room where the water heater is located, or combustion air is taken from one of the areas listed, the contaminants must be removed immediately or the intake pipe must be relocated to another area.

Ensure the Water Heater Cabinet is Closed

Ensure the water heater cabinet is closed. Tighten the two upper and lower screws to secure it. The cabinet must be closed while the water heater is running.

Check the Power Source

Make sure the power cord is properly connected. The main power line is connected to the manual switch box inside the water heater.

Check the Status of the Control Panel

Observe the Control Panel to ensure the water heater is powered on, and to check for any error codes. Clear any debris from the panel.

Check Exhaust Vent and Intake Pipe Terminations

Verify that the water heater exhaust vent and intake pipe terminations are clean and free of obstructions. Remove any debris from the exhaust vent or intake pipe openings. If removing the debris does not allow the water heater to operate correctly, contact your qualified service technician to inspect the water heater and the vent system.

Check Exhaust Vent and Intake Piping

Visually inspect the exhaust vent for any signs of blockage, leakage, or deterioration of the piping. Inspect the exhaust vent bracing. Ensure bracing is undamaged and in good condition. Notify a qualified service technician immediately if any problems are found.

WARNING

Failure to inspect the venting system and have it repaired by a qualified service technician can result in vent system failure, causing severe personal injury or death.

Visually inspect the intake piping for any signs of blockage. Inspect the entire length of the intake pipe to ensure piping is intact and all joints are properly sealed. Inspect the intake pipe bracing. Ensure bracing is undamaged and in good condition. Notify a qualified service technician if any problems are found.

Check Pressure Relief Valve

- Visually inspect the primary pressure relief valve and discharge pipe for signs of weeping or leakage.
- If the pressure relief valve often weeps, the expansion tank may not be operating properly. Immediately contact a qualified service technician to inspect the water heater and system.

Check the Condensate Drain System

- While the water heater is running, check the discharge end of the condensate drain tubing. Ensure no flue gas is leaking from the condensate drain tubing by holding your fingers near the opening.
- If you notice flue gas leaking from the opening, this indicates a dry condensate drain trap. If problem persists, contact a qualified service technician to inspect the water heater and condensate line and refill the condensate trap.
- If applicable, check the condensate neutralizer and ensure it is full of condensate neutralizing marble chips.

Cleaning the Air Intake Filter

The air intake filter should be cleaned once a month. If not, the water heater could encounter combustion problems.

To clean the air intake filter:

1. Press the Power button on the control panel to turn off the water heater.
2. Disconnect the power supply from the water heater.
3. If water heater has been operating, wait for it to cool before continuing.
4. Remove the front cover of the water heater cabinet.
5. Pull the filter screen screw and pull the filter out of the air intake adapter.
6. Remove the filter from the plastic assembly and clean it with a toothbrush and clean running water. See Figure.

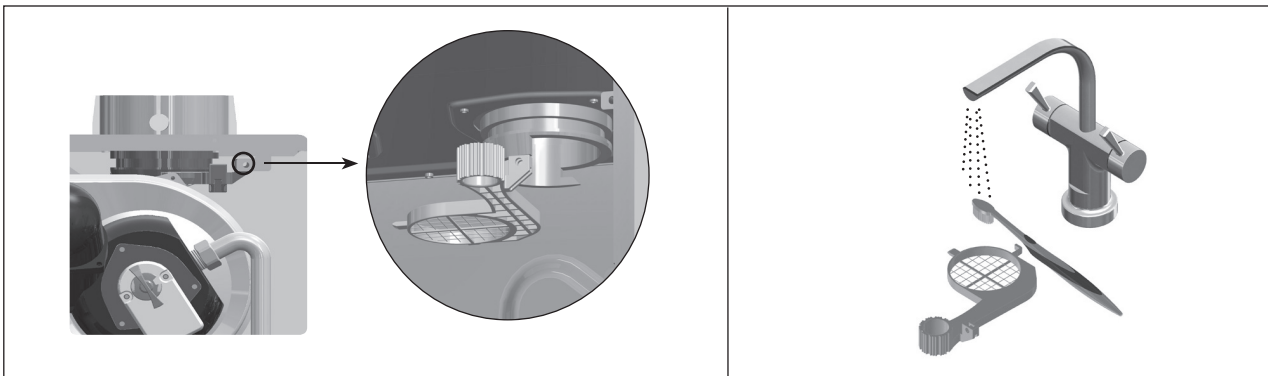

Figure - Cleaning the Air Intake Filter

7. Dry the filter completely. Then reinsert the filter into the plastic assembly.
8. Replace the front cover of the water heater cabinet. Reconnect power supply to the water heater.
9. Press the Power button on the control panel to turn on the water heater.

Check Primary and Gas Piping

- Remove the water heater cover and perform a gas leak inspection following Operating Instructions, page 2, this manual. If gas odor or leak is detected, follow procedures on page 2. Call a qualified service technician.
- Visually inspect for leaks around the internal water heater water connections and around the heat exchanger. Visually inspect the external system piping, circulators, and system components and fittings. Immediately call a qualified service technician to repair any leaks.

3. Flushing the Water Heater

Flushing the Water Heater

Flushing the heat exchanger is a complicated procedure that should only be performed by a qualified service technician.

NOTE: Improper maintenance WILL VOID water heater warranty.

1. Disconnect electrical power to the water heater.
2. Close the shutoff valves on both hot water outlet and cold water inlet lines (V1 and V2). See Figure 57.
3. Connect one hose (D1, Figure 57) to the valve (V3) and place the free end in a bucket. Connect one of the hoses (D3) to the circulation pump outlet and the cold water inlet line to valve V4. Connect the other hose (D2) to the circulation pump inlet and place the free end in the bucket.

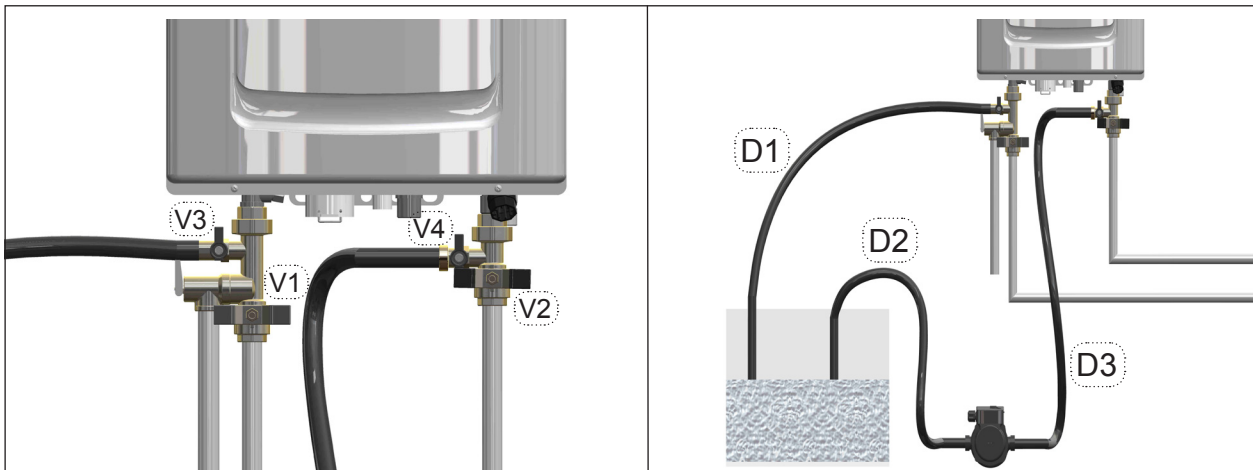
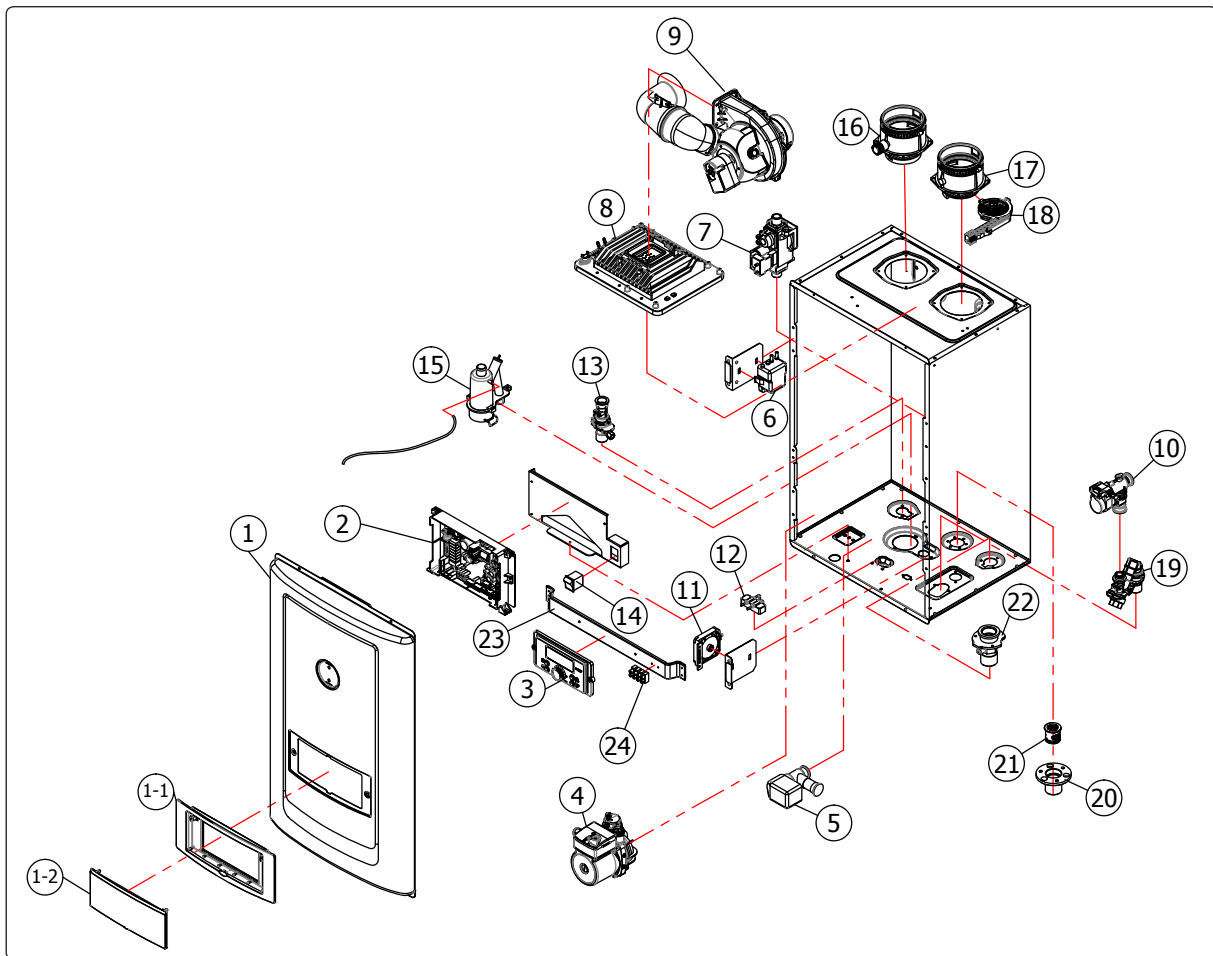

Figure – Flushing the Water Heater

4. Pour tankless water heater cleaning solution into the bucket. Ensure the cleaning solution is approved for potable water systems. Place the drain hose (D1) and hose D2 to the pump inlet in the cleaning solution.
5. Open service valves (V3 and V4) on the hot water outlet and cold water inlet lines.
6. Turn on the circulation pump. Operate the pump and allow the cleaning solution to circulate through the water heater for at least 1 hour at a rate of 4 gallons per minute. This will remove any possible harmful scale deposits.
7. Rinse the cleaning solution from the combination water heater as follows:
 - a. Remove the free end of drain hose D1 from the bucket.
 - b. Close service valve V4 and open shutoff valve V2.
 - c. Do not open shutoff valve V1.
 - d. Allow water to flow through the water heater for 5 minutes.
 - e. Close shutoff valve V2.
8. Disconnect all hoses.
9. Remove the cold water inlet filter from the water heater and clean out any residues.
10. Reinsert the filter and ensure the filter cap is securely tightened.
11. Connect electrical power to the water heater.
12. Open a hot water faucet. Run the water heater continuously for five minutes to ensure all cleaning solution is purged from the system. Check for leaks and ensure the water heater is operating properly.

PART I _ CASE PART



Ref #	Description
1.	Front Cover
1-1.	Control Panel Bracket
1-2.	Control Panel Window
2.	PCB
3.	Control Panel
4.	Circulation Pump
5.	Mixing Valve
6.	Igniter
7.	Gas Valve Assembly
8.	Burner Assembly
9.	Blower & Silencer
10.	Flow Control Valve
11.	Air Pressure Switch
12.	Water Leak Detector

Ref #	Description
13.	Hot Water Pipe Assembly
14.	Rocker Switch
15.	Condensate Trap
16.	Exhaust Assembly
17.	Air Intake Assembly
18.	Air Intake Filter
19.	Cold Water Valve Assembly
20.	Recirculation Return Connection
21.	Check Valve
22.	Gas Inlet Connection
23.	Control Panel Steel Bracket
24.	Terminal Block

Service Manual



RHEEM AMERICA Corporation